

ThorburnFlex



Clean Power Generation



Petrochemical Processing



Hydro/Pyro Metallurgical Processing

METALLIC HOSE ASSEMBLIES Engineered Solutions For Pipe Motion



www.thorburnflex.com



ThorburnFlex

Thorburn Flex is an innovative manufacturer of specialized engineered flexible piping systems (i.e. custom hose assemblies and expansion joints). Since 1954, Thorburn’s corporate mission evolution and business philosophy have been customer driven and targeted to select niche applications where Thorburn can achieve clear positions of sustainable technological and market share leadership. Thorburn Flex is committed to a policy of continuous development and research to provide engineered solutions for pipe motion that set the industry standards for quality, safety, environmental protection, durability and value.



European
Conformity



ISO
9001



B31.1,
B31.3



ASME “NPT”
Sec. III Class 1



ASME “U”
Sec. VIII Div. 1



N285.0, B51
CGA CR96-001



97/23/EC
Module H



UL
536

ISCIR Romania | CNCAN Romania | EN 13480-2002 | HAF 604 China | TSG China

www.thorburnflex.com

Table Of Contents

Introduction

Engineered Metallic Hose Assemblies	4
Hose Core Forming	5
Tight Weave Braid Design	6
Specialty Metallic Hose Assemblies	7

Metallic Corrugated Hose

(N)S95/(N)S91 Stainless Steel Annular	8
(N)H95 Hastelloy C276 Annular	10
(N)I95 Inconel 625 Annular	11
(N)M95 Monel Annular	12
(N)B95 Bronze Annular	13
(N)S65 Extra Flex Helical	14
(N)S81 High Pressure Stainless Steel Annular	15
(N)S98Z Ultra High Pressure Fully Compressed Annular	16
(N)S99Z High Pressure Fully Compressed Annular	17
(N)S50HD Ultra High Pressure Compressed Helical	18
(N)S69 Annular Closed Pitch Omega	19
LS Series - Lock Section	20
AF Series - Ball Joint Armor-Flex™ Hose Guard	21
SFM Series - Smooth-Flex	22
FJ72 Fry-Sil Fire Jacket & FJ73 Fry-Sil Tape	23

Metallic Hose Ends

Standard Fitting To End Joints	24
How to Order Thorburn Corrugated Metal Hose Assemblies	28

Special Purpose Hose Assemblies

(N)S40 Oxylance™ - Oxygen Lance Hose Assemblies	29
Cryogenic Carbon Dioxide Connectors	30
Cryogenic Fittings - Nitrogen, Oxygen & Argon Liquid Transfer	32
Cryogenic Unloading Hose Assemblies	34
Steam Jacketed (Double Containment) Hose Assemblies	35
Sure-Temp Electrically Heated Metallic Hose Assemblies	36
ThermaCover™ Removable Thermal Insulation Covers	37
M96ZC Series - Monel Chlorine Transfer Hose Assemblies	38
CGA96/UL96 Series - Metal Hose Assemblies	39
Thor-Loop™ Flexible Pipe Loops	40

Technical Data

Metal Hose Technical Data	42
Installing Thorburn Hose Assemblies	44
Pipe Anchoring Guide	45
Selection Factors	46
Thermal Expansion of Pipe	47

Quick Couplings

(N)TS25 Series - Thor-Sight Sight Flow Indicator	48
(N)BC Series - Big Cam™ Camlock Flanged Couplings	49
(N)T92H Series Dry Break Quick Coupling	50
(N)TS2 Series - Non-Valved Full Flow Cryogenic Couplings	53
MT3TL Series - Met-O-Seal	54
MTS4 Series - Met-O-Seal	55
(N)UO Series - O-Seal™ Never Leak Pipe Unions	56
Guard-Lok Series - Camlock Quick Couplings	58
Camlock Elbow Quick Couplings	64
Bottom Loading Accessories	65
SJ Series - Swivel Joints	66

Technical Data

Types Of Corrosion	68
Corrosion Resistance Tables	70
Material Selection At A Glance	78



Engineered Metallic Hose Assemblies



Thorburn's design team uses FEA & Solidworks to provide engineered pipe motion solutions



Automated tube forming & welding



Automated fitting to end joint orbital welding

Engineering Capabilities & Experience

Thorburn's design engineering expertise is supported by advanced FEA software that offers powerful and complete solutions for both routine and sophisticated engineering problems. Thorburn's engineers can analyse and provide innovative solutions for pipe and duct motion problems including dynamic vibration, nonlinear static, linear static, thermal gradient through material wall thickness, acoustic impedance and fatigue using a common model data structure and integrated solver technology.

Fabrication Certification

- Welders and welding procedures: ASME Section IX, VIII, B31.1, B31.3, CSA B51 and Section III NPT (in progress)
- EN13480-2002: European Industrial Metallic Piping Standard & 97/23/EC (Pressure Equipment Directive)
- Canadian Gas Association (CGA) Certification: Standards CAN/CGA-8.1-M86, CGA96, UL96, UL536
- ISO 10380 Corrugated Metal Hose & Hose Assemblies
- Pressure Vessel Certification: CRN OH0012. All Canadian Provinces & Territories
- Monel Chlorine Transfer: Chlorine Institute Specification 135-3
- Hose Assemblies Degreased, Cleaned and Capped for Oxygen or Chlorine Service

Quality Assurance Certification & Compliance

- CSA N299.1, ISO 9001, ASME Section III, ASME Section VIII, Div 1 CSA B51, NCA 4000 NQA-1, CSA N285.0

Design & Materials

- ASME Code Sections I, II, III, VIII, IX, B31.1 & B31.3
- ISO 10380 Corrugated Metal Hose & Hose Assemblies
- NACE MRO175-2009/ISO 15156-2009 compliance
- FEA - Finite Element Analysis

Welding and Fabrication Capabilities

- Arc, Pulse Arc, TIG, MIG, Core Wire
- Tube Welding, Track Welding, Automated Flame Cutting & Welding
- Rolls, Positioners, Turntables
- Automated Tube Welding DIN 6mm (1/4") to DIN 300mm (12")
- Hydro-Forming Convolutions DIN 25mm (1") to DIN 750mm (30")
- Mechanical Forming Convolutions DIN 6mm (1/4") to DIN 300mm (12")

NDT/NDE Programs & Design Verification Testing

- Weld X-Ray to 300KV-5MA / Welds Dye Penetrant to ASME Sec V
- Vacuum Testing 29.9" HG and Hydrostatic or Nitrogen Pressure Testing to 1,000 bar (15,000 psi)
- Impulse Testing to 680 bar (10,000 psi) at 204°C (400°F).
- Burst Testing up to 4,000 bar (60,000 psi)
- Pliability Fatigue & Deflection Testing ISO 10380:2012
- Seismic & Vibration Analysis in Acceptance with ASME Sec III
- Helium Mass Spectrometer Leak Testing

Hose Core Forming

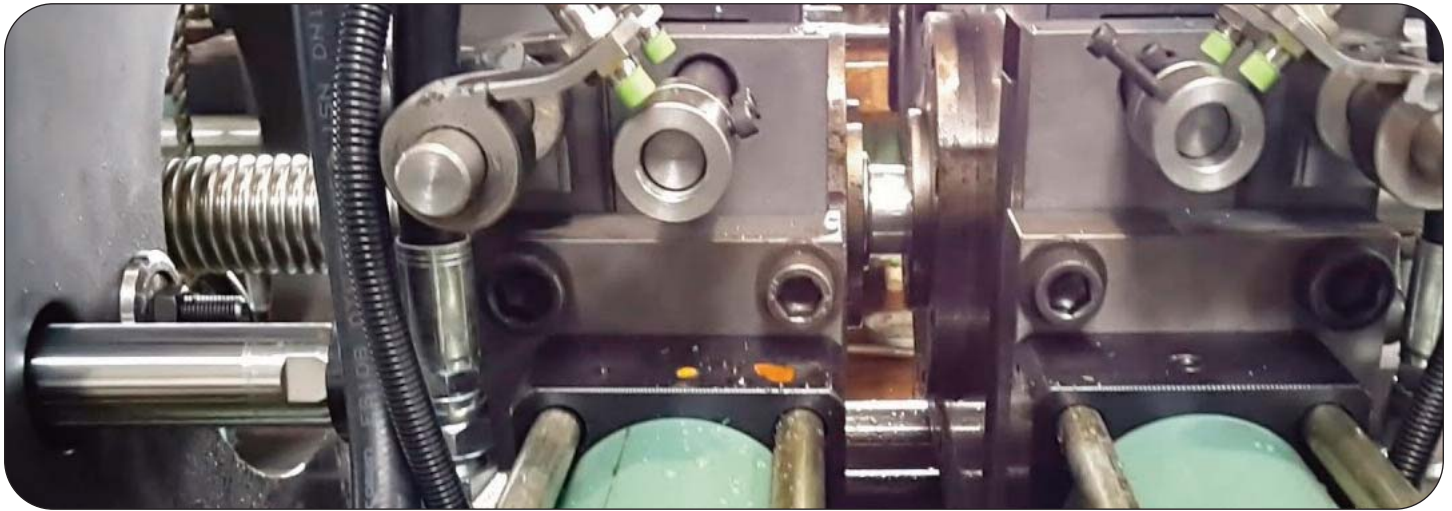

Thorburn's standard annular flexible core starts its life as a coil of metal strip which is mechanically formed into a tube and then longitudinally butt welded. Considerable care is taken to ensure that the strength of the butt weld is greater than that of the parent material. This rigid tube is then transferred to the corrugating machine where the corrugations are formed. After the tube has been corrugated, it is pressure tested to ensure that there are no leaks.

Thorburn's Hydroforming Corrugation Process

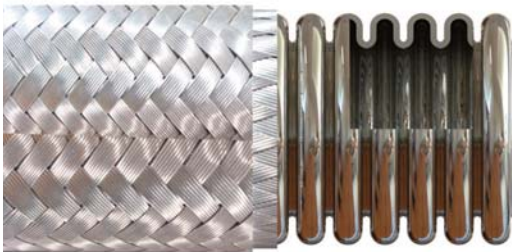

*Annular profile Corrugations
Independent corrugations straight & parallel*



Thorburn's hydroforming corrugations are formed by expanding a section of the welded tube with high pressure water from inside the tube, while simultaneously feeding the tube axially into the process. Hydroforming is a clean, gentle process that enhances flexibility and cycle life, maintains wall thickness, reduces concentrated residual stress, and minimizes work hardening of materials.

Thorburn's Mechanical Corrugation Process

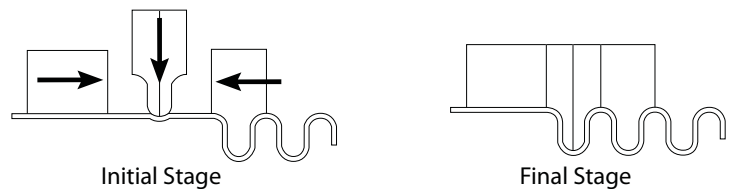
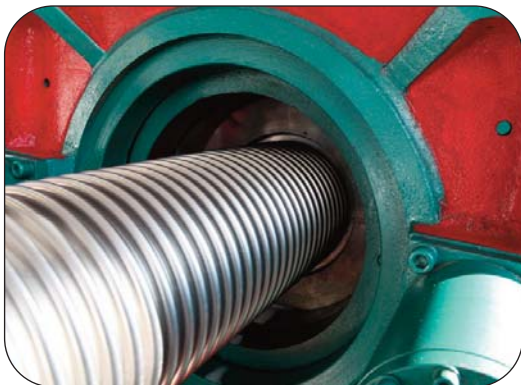

Thorburn's mechanical corrugation forming process forms from the exterior by compressing a section of welded tube while simultaneously synchronizing a bi-directional feed of the tube axially into the process. This process yields a hose with uniform wall thickness, enhanced flexibility and cycle life, without imparting residual torsional stress common with other manufacturing methods.

Tight Weave Braid Design



Thorburn uses a range of braiding machines (24, 36, 48, 64, 96 & 128 carriers), with the ability to produce top quality braid from 6mm (1/4") to 350mm (14") nominal size diameter.

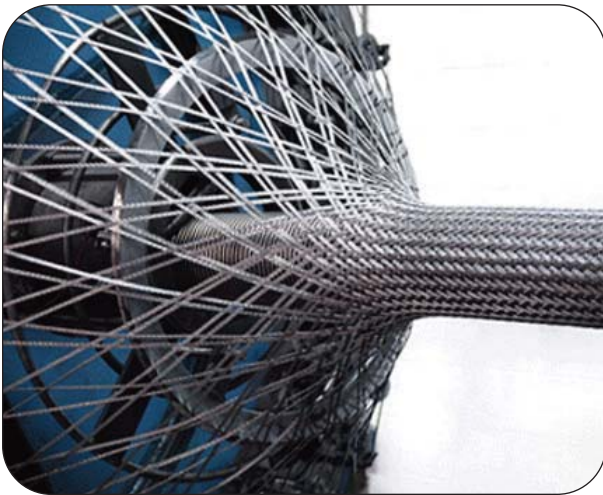

Close up view of a metallic hose core being braided

Superior Technology Working for You!

The braid is the principal reinforcement component in our metallic hose. Our engineers design our braid's construction to optimize coverage, angle, wire thickness and number of wires to maximize pressure containment in all our metallic hose assemblies. Braid covers the exterior of a hose, increasing the resistance to elongation and the hoses' internal pressure capabilities.

Thorburn's hose assemblies go through rigorous batch testing including burst, leak and hydrostatic testing to confirm theoretical calculations with actual test results.

After the attachment of the end fittings, each metal hose assembly is pressure tested to 1.5 times design pressure and test certificates can be supplied.

Braided Braid

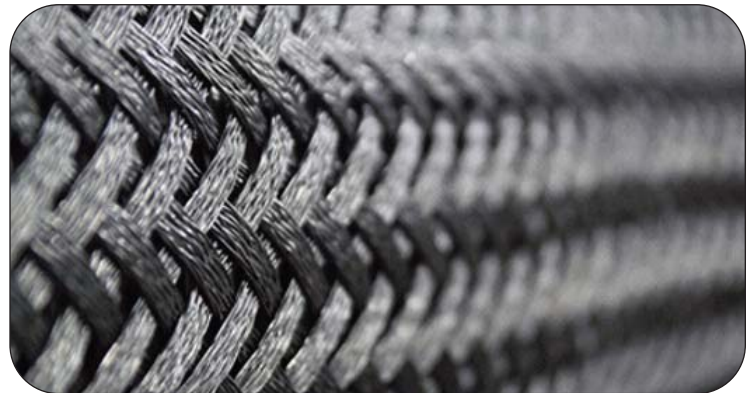

Sizes 150mm (6") nominal size DN and above are made as braided braid, manufactured by initially weaving single steel wire into braid strands. These strands are themselves woven to form the final braid resulting in a highly stable and flexible construction.

Typical Applications



Power Generation



LNG Transfer

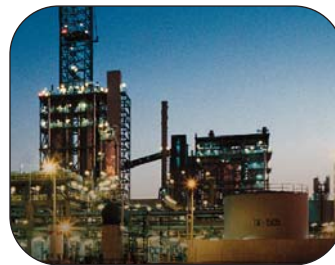

Petro-Chemical Processing



Pulp & Paper Processing

Specialty Metallic Hose Assemblies



Thorburn's Model TSJ Steam Jacketed Hose Assemblies

Engineered Solutions For Pipe Motion

Purpose

Thorburn's custom metal hose assemblies are made up of three major parts: corrugated metal tube over braid and end fittings. Thorburn metallic hose assemblies achieve several objectives in pipe work design: absorb vibration, suppress rigid pipe transmitted noise, accommodate reciprocating and flexing movement and adjust or correct for minor misalignment.

Custom Designs

Thorburn provides end-user engineered solutions for pipe motion. You specify the operating conditions and we will produce a custom metal hose assembly that will satisfy the operating conditions. Thorburn's metal hose assemblies may be exceptionally flexible or you may need several hoses encapsulated in outer hose: a jacketed hose for heat exchange; an armoured hose; a hose to carry sensitive cables; an articulated robotic cover; an insulated hose; a colour coded hose. Our "Can-Do" design specialists are only a phone call away.

Hose

Thorburn's manufactured annular corrugated hose tends to be more flexible and lower stressed than a helical product. Thorburn's metal hose pitch can be varied to meet specific application requirements such as flexibility and pressure rating

End Fittings

The fitting to end joints are the means by which Thorburn's custom designed assemblies are attached into the pipework system.

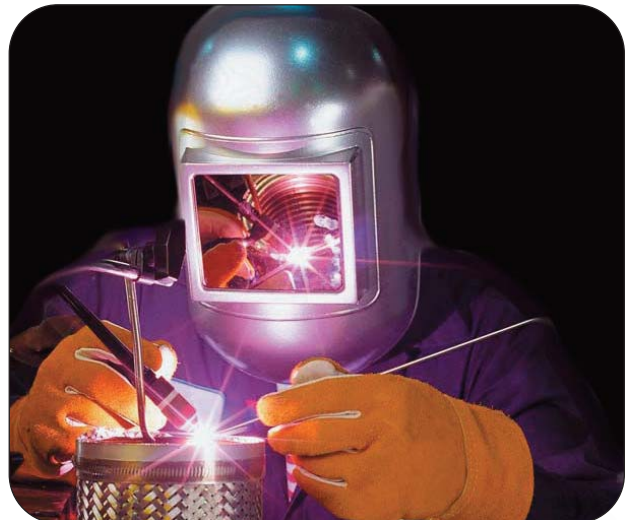

Thorburn's welders & welding procedures are certified to ASME Section IX



Flexibility you can count on!

(N)S95/(N)S91 Stainless Steel Annular



Type 321 - Hose with SS304 Braid

(N)S95 - Unbraided inner core	0
(N)S96 - Braided hose	1
(N)S96Z - Double braided hose	2

Type 316L - Hose with SS316L Braid

(N)S91 - Unbraided inner core	0
(N)S93 - Braided hose	1
(N)S93Z - Double braided hose	2

Type 316L - Hose with SS304 Braid

(N)S91 - Unbraided inner core	0
(N)S92 - Braided hose	1
(N)S92Z - Double braided hose	2

Canadian Registration (All Provinces)
CRN 0H0012.1.2.3.4.5.6.7.8.9.10

Test Pressure: 1.5 X design pressure



Thorburn Model NS96Z installed in a nuclear power plant

Construction

- Medium wall annular/standard pitch
- Butt weld tubing

Features

- 4 to 1 safety factor over design pressures
- Sizes 6mm (1/4") to 750mm (30")

Nominal ID		Hose Type	Hose OD		Bend Radius				Live Length for Vibration		Design Pressure		Weight	
					Static Bend		Constant Flexing							
mm	in	Code	mm	in	mm	in	mm	in	mm	in	bar	psi	kg/m	lbs/ft
6	1/4	0	12.2	0.48	25.4	1	127.0	5	101.6	4	13.1	180	0.13	0.09
		1	14.5	0.57							145.9	2116	0.25	0.17
		2	16.3	0.64							215.5	3125	0.37	0.26
10	3/8	0	16.0	0.63	38.1	1.5	152.4	6	152.4	6	6.9	100	0.19	0.13
		1	17.8	0.70							103.5	1501	0.37	0.25
		2	20.6	0.81							165.5	2401	0.54	0.36
12.7	1/2	0	20.8	0.82	40.6	1.6	152.4	6	152.4	6	5.5	80	0.34	0.23
		1	22.6	0.89							74.1	1075	0.51	0.34
		2	24.4	0.96							118.6	1720	0.68	0.46
19	3/4	0	30.7	1.21	57.2	2.25	203.2	8	177.8	7	4.8	70	0.58	0.39
		1	32.5	1.28							54.6	792	0.88	0.59
		2	34.3	1.35							87.4	1267	1.18	0.79
25	1	0	38.4	1.51	69.9	2.75	228.6	9	177.8	7	2.8	40	0.79	0.53
		1	40.1	1.58							39.4	571	1.12	0.75
		2	41.9	1.65							63.0	914	1.46	0.98
32	1 1/4	0	46.9	1.85	88.9	3.5	254.0	10	203.2	8	1.7	25	1.13	0.76
		1	49.0	1.93							36.6	531	1.59	1.07
		2	51.3	2.02							58.6	850	2.04	1.37
40	1 1/2	0	55.6	2.19	101.6	4.0	304.8	12	203.2	8	1.4	20	1.40	0.84
		1	57.9	2.28							32.5	472	1.83	1.23
		2	60.2	2.37							52.1	755	2.43	1.63
51	2	0	66.0	2.60	127.0	5.0	381.0	15	228.6	9	1.	15	1.34	0.90
		1	69.1	2.72							35.6	516	2.26	1.52
		2	72.1	2.84							57.0	826	3.18	2.14

Notes: 1. Suffix (N) is used with CRN. Pressures may be different than shown depending on method of fitting to end joint welding. Consult Thorburn for details. 2. Each hose assembly is pressure tested with demineralized water 1.5 X design pressure. 3. Use of Thorburn's flexible metal hose assemblies should be undertaken only after thorough engineering analysis, prototyping and approval by end user.

(N)S95/(N)S91 Stainless Steel Annular

Nominal ID		Hose Type Code	Hose OD		Bend Radius				Live Length for Vibration		Design Pressure		Weight	
mm	in		mm	in	Static Bend		Constant Flexing		mm	in	bar	psi	kg/m	lbs/ft
63.5	2 1/2	0	82.0	3.23	203.2	8.00	508.0	20.00	254	10	0.8	12	1.73	1.16
		1	84.6	3.33							26.7	387	2.77	1.86
		2	87.1	3.43							42.7	619	3.81	2.56
80	3	0	96.0	3.78	228.6	9.00	558.8	22.00	279.4	11	0.7	10	1.80	1.21
		1	98.6	3.88							21.8	316	2.98	2.00
		2	101.1	3.98							34.9	506	4.17	2.80
90	3 1/2	0	109.7	4.32	254.0	10.00	609.6	24.00	279.4	11	0.6	9	2.41	1.62
		1	113.0	4.45							20.5	297	3.88	2.61
		2	116.3	4.58							32.7	475	5.36	3.60
100	4	0	123.2	4.85	330.2	13.00	685.8	27.00	304.8	12	0.6	8	2.51	1.69
		1	126.5	4.98							16.0	232	3.99	2.68
		2	129.5	5.10							25.6	371	5.48	3.68
125	5	0	149.9	5.90	457.2	18.00	787.4	31.00	406.4	16	0.4	6	3.72	2.50
		1	153.2	6.03							13.2	191	5.58	3.75
		2	156.2	6.15							21.1	306	7.44	5.00
150	6	0	174.5	6.87	482.6	19.00	914.4	36.00	431.8	17	0.3	5	5.16	3.47
		1	180.3	7.10							11.4	165	7.07	4.75
		2	186.2	7.33							18.2	264	8.99	6.04
200	8	0	230.9	9.09	508.0	20.00	1016.0	40.00	482.6	19	0.4	6	8.27	5.56
		1	233.4	9.19							16.1	234	14.05	9.44
		2	235.7	9.28							25.8	374	19.88	13.36
250	10	0	284.0	11.18	635.0	25.00	1270.0	50.00	533.4	21	0.3	5	10.12	6.80
		1	287.5	11.32							15.9	230	19.20	12.90
		2	290.8	11.45							25.3	367	28.28	19.00
300	12	0	334.5	13.17	762.0	30.00	1524.0	60.00	584.2	23	0.2	3	13.42	9.02
		1	338.1	13.31							11.1	161	22.07	14.83
		2	341.4	13.44							17.7	257	30.72	20.64
350	14	0	373.4	14.70	889.0	35.00	1778.0	70.00	635.0	25	0.2	3	20.98	14.10
		1	376.9	14.84							8.2	119	32.29	21.70
		2	380.5	14.98							13.1	190	43.60	29.30
400	16	0	415.8	16.37	1066.8	42.00	1879.6	74.00	685.8	27	0.1	2	27.73	18.64
		1	422.1	16.62							7.6	110	37.26	25.04
		2	428.2	16.86							11.7	170	46.78	31.44
450	18	0	476.3	18.75	1193.8	47.00	2082.8	82.00	736.6	29	.07	1	36.39	24.45
		1	482.6	19.00							5.9	85	45.91	30.85
		2	489.0	19.25							10.3	150	55.43	37.25
600	24	0	628.7	24.75	1574.8	62.00	2641.6	104.00	889.0	35	.07	1	55.98	37.62
		1	635.0	25.00							3.1	45	66.16	44.46
		2	641.4	25.25							5.5	80	80.81	54.30
750	30	0	781.1	30.75	1905.0	75.00	3251.2	128.00	1092.2	43	.05	0.75	86.13	57.88
		1	787.4	31.00							1.4	20	98.81	66.40
		2	793.8	31.25							2.5	36	116.88	78.54

Notes: 1. Suffix (N) is used with CRN. Pressures may be different than shown depending on method of fitting to end joint welding. Consult Thorburn for details. 2. Each hose assembly is pressure tested with demineralized water 1.5 X design pressure. 3. Use of Thorburn's flexible metal hose assemblies should be undertaken only after thorough engineering analysis, prototyping and approval by end user.

(N)H95 Hastelloy C276 Annular



Hastelloy C276 is among the most corrosive resistant alloys available. It is used in challenging application found in power generation, steel & petrochemical industries

Hastelloy Type C276 with C276 Braid

- (N)H95 Unbraided inner core 0
- (N)H96 Braided hose 1
- (N)H96Z Double braided hose 2

Hastelloy Type C276 with SS304 Braid

- (N)HS95 Unbraided inner core 0
- (N)HS96 Braided hose 1
- (N)HS96Z Double braided hose 2

Test Pressure: 1.5 X design pressure

Construction

- Medium wall butt welded tubing
- Standard pitch annular corrugations
- 4 to 1 safety factor over working pressures

Canadian Registration: Available upon request (All Provinces)



Thorburn HS96Z hose used in a chemical unloading station

* Hastelloy C276 Material on special order only - Minimum quantities will apply. Consult Thorburn Flex for details

Nominal ID		Hose Type	Hose OD		Bend Radius				Live Length for Vibration		Working Pressure		Weight	
					Static Bend		Constant Flexing							
mm	in	Code	mm	in	mm	in	mm	in	mm	in	bar	psi	kg/m	lbs/ft
12.7	1/2	0	20.8	.82	63.5	2.50	127.0	5.00	152.4	6	5.5	80	0.37	0.25
		1	22.6	.89							74.1	1075	0.57	0.38
		2	24.4	.96							118.6	1720	0.76	0.51
19	3/4	0	30.7	1.21	76.2	3.00	152.4	6.00	177.8	7	4.8	70	0.64	0.43
		1	32.5	1.28							54.6	792	0.97	0.65
		2	34.3	1.35							87.4	1267	1.29	0.87
25	1	0	38.4	1.51	92.7	3.65	185.4	7.30	203.2	8	2.8	40	0.86	0.58
		1	40.1	1.58							39.4	571	1.24	0.83
		2	41.9	1.65							63.2	916	1.61	1.08
40	1 1/2	0	55.6	2.19	109.2	4.30	218.4	8.60	228.6	9	1.4	20	1.37	0.92
		1	57.9	2.28							32.5	472	2.01	1.35
		2	60.2	2.37							52.1	755	2.66	1.79
51	2	0	66.0	2.60	152.4	6.00	304.8	12.00	254.0	10	1.0	15	1.49	1.00
		1	69.1	2.72							35.6	516	2.49	1.67
		2	72.1	2.84							57.0	826	3.50	2.35
80	3	0	98.6	3.88	198.1	7.80	457.2	18.00	279.4	11	0.9	14	1.76	1.18
		1	101.1	3.98							23.9	346	3.07	2.06
		2	103.6	4.08							35.8	519	4.38	2.94
100*	4*	0	126.0	4.96	248.9	9.80	558.8	22.00	304.8	12	0.9	14	2.10	1.41
		1	128.5	5.06							20.6	299	3.68	2.47
		2	131.1	5.16							30.9	448	5.25	3.53
125*	5*	0	152.4	6.00	325.1	12.80	711.2	28.00	406.4	16	0.9	14	3.24	2.18
		1	155.4	6.12							19.0	275	5.37	3.61
		2	158.5	6.24							28.4	412	7.50	5.04
150*	6*	0	178.1	7.01	375.9	14.80	812.8	32.00	431.8	17	0.8	11	4.00	2.69
		1	181.1	7.13							14.5	210	6.61	4.44
		2	184.9	7.28							21.7	315	9.21	6.19

Notes: 1. Suffix (N) is used with CRN. Pressures may be different than shown depending on method of fitting to end joint welding. Consult Thorburn for details. 2. Each hose assembly is pressure tested with demineralized water 1.5 X design pressure. 3. Use of Thorburn's flexible metal hose assemblies should be undertaken only after thorough engineering analysis, prototyping and approval by end user.

(N)I95 Inconel 625 Annular



Thorburn's Inconel 625 typical applications include chemical processing, aerospace, marine engineering, pollution abatement systems and nuclear reactors.

Thorburn's Inconel 625 metallic hose resists a wide range of severely corrosive environments and is especially resistant to pitting, crevice corrosion & oxidation.

Inconel Type 625 with Inconel Braid

(N)I95 Unbraided inner core	0
(N)I96 Braided hose	1
(N)I96Z Double braided hose	2

Inconel Type 625 with SS304 Braid

(N)IS95 Unbraided inner core	0
(N)IS96 Braided hose	1
(N)IS96Z Double braided hose	2

Construction

- Medium wall butt welded tubing
- Standard pitch annular corrugations
- 4 to 1 safety factor over working pressures

Test Pressure: 1.5 X design pressure

Canadian Registration: Available upon request (All Provinces)

Nominal ID		Hose Type	Hose OD		Bend Radius				Live Length for Vibration		Working Pressure		Weight	
					Static Bend		Constant Flexing							
mm	in	Code	mm	in	mm	in	mm	in	mm	in	bar	psi	kg/m	lbs/ft
6	1/4	0	12.2	0.48	25.4	1	127.0	5	101.6	4	13.1	180	0.13	0.09
		1	14.5	0.57							145.9	2116	0.25	0.17
		2	16.3	0.64							215.5	3125	0.37	0.26
10	3/8	0	16.0	0.63	38.1	1.5	152.4	6	152.4	6	6.9	100	0.19	0.13
		1	17.8	0.70							103.5	1501	0.37	0.25
		2	20.6	0.81							165.5	2401	0.54	0.36
12.7	1/2	0	20.8	0.82	40.6	1.6	152.4	6	152.4	6	5.5	80	0.34	0.23
		1	22.6	0.89							74.1	1075	0.51	0.34
		2	24.4	0.96							118.6	1720	0.68	0.46
19	3/4	0	30.7	1.21	57.2	2.25	203.2	8	177.8	7	4.8	70	0.58	0.39
		1	32.5	1.28							54.6	792	0.88	0.59
		2	34.3	1.35							87.4	1267	1.18	0.79
25	1	0	38.4	1.51	69.9	2.75	228.6	9	177.8	7	2.8	40	0.79	0.53
		1	40.1	1.58							39.4	571	1.12	0.75
		2	41.9	1.65							63.0	914	1.46	0.98
32	1 1/4	0	46.9	1.85	88.9	3.5	254.0	10	203.2	8	1.7	25	1.13	0.76
		1	49.0	1.93							36.6	531	1.59	1.07
		2	51.3	2.02							58.6	850	2.04	1.37
40	1 1/2	0	55.6	2.19	101.6	4.0	304.8	12	203.2	8	1.4	20	1.40	0.84
		1	57.9	2.28							32.5	472	1.83	1.23
		2	60.2	2.37							52.1	755	2.43	1.63
51	2	0	66.0	2.60	127.0	5.0	381.0	15	228.6	9	1.	15	1.34	0.90
		1	69.1	2.72							35.6	516	2.26	1.52
		2	72.1	2.84							57.0	826	3.18	2.14
63.5	2 1/2	0	82.0	3.23	203.2	8.00	508.0	20.00	254	10	0.8	12	1.73	1.16
		1	84.6	3.33							26.7	387	2.77	1.86
		2	87.1	3.43							42.7	619	3.81	2.56
80	3	0	96.0	3.78	228.6	9.00	558.8	22.00	279.4	11	0.7	10	1.80	1.21
		1	98.6	3.88							21.8	316	2.98	2.00
		2	101.1	3.98							34.9	506	4.17	2.80
100	4	0	123.2	4.85	330.2	13.00	685.8	27.00	304.8	12	0.6	8	2.51	1.69
		1	126.5	4.98							16.0	232	3.99	2.68
		2	129.5	5.10							25.6	371	5.48	3.68

Notes: 1. Suffix (N) is used with CRN. Pressures may be different than shown depending on method of fitting to end joint welding. Consult Thorburn for details. 2. Each hose assembly is pressure tested with demineralized water 1.5 X design pressure. 3. Use of Thorburn's flexible metal hose assemblies should be undertaken only after thorough engineering analysis, prototyping and approval by end user.

(N)M95 Monel Annular



Monel 400 Hose with Monel Braid

- (N)M95 - Unbraided inner core **0**
- (N)M96 - Braided hose **1**
- (N)M96Z - Double braided hose **2**

Test Pressure: 1.5 X design pressure

Construction

- Medium wall butt welded tubing
- Standard pitch annular corrugations
- 4 to 1 safety factor over working pressures

Canadian Registration: Available upon request
(All Provinces)

Thorburn’s (N)M95 Monel metallic braided hose are made from nickel-copper alloy providing high strength and excellent corrosion resistance to a wide range of media including seawater, hydrofluoric acid, sulphuric acid, dry chlorine and alkaline. Thorburn’s core and braid material is Monel 400 and meets material requirements of the Chlorine Institute Pamphlet 6.



Thorburn’s (N)M95 Monel hose assembly attached to a rail loading arm

Nominal ID		Hose Type	Hose OD		Bend Radius				Live Length for Vibration		Working Pressure		Weight	
					Static Bend		Constant Flexing							
mm	in	Code	mm	in	mm	in	mm	in	mm	in	bar	psi	kg/m	lbs/ft
6	1/4	0	12.7	0.50	63.5	2.50	127.0	5.00	101.6	4	9.9	144	0.13	0.09
		1	14.5	0.57							118.7	1722	0.28	0.19
		2	16.3	0.64							190.0	2755	0.43	0.29
12.7	1/2	0	20.8	0.82	101.6	4.00	203.2	8.00	152.4	6	4.4	64	0.58	0.39
		1	22.9	0.90							51.1	741	0.94	0.63
		2	24.9	0.98							81.8	1186	1.29	0.87
19	3/4	0	30.7	1.21	101.6	4.00	203.2	8.00	177.8	7	10.8	156	0.71	0.48
		1	32.8	1.29							43.4	629	1.18	0.79
		2	35.1	1.38							69.4	1006	1.64	1.10
25	1	0	38.1	1.50	114.3	4.50	228.6	9.00	203.2	8	2.2	32	1.18	0.79
		1	40.1	1.58							35.6	517	1.49	1.00
		2	42.2	1.66							57.0	827	1.79	1.20
40	1 1/2	0	55.6	2.19	152.4	6.00	304.8	12.00	228.6	9	1.1	16	1.25	0.84
		1	57.7	2.27							23.6	343	1.9	1.28
		2	59.7	2.35							37.9	549	2.56	1.72
51	2	0	66.0	2.60	190.5	7.50	381.0	15.00	254.0	10	0.8	12	1.55	1.04
		1	65.8	2.59							25.9	376	2.56	1.72
		2	67.8	2.67							41.5	602	3.57	2.40
80	3	0	96.0	3.78	279.4	11.00	558.8	22.00	279.4	11	0.6	8	1.8	1.21
		1	98.6	3.88							15.2	221	3.04	2.04
		2	101.1	3.98							24.4	354	4.27	2.87

Notes: 1. Suffix (N) is used with CRN. Pressures may be different than shown depending on method of fitting to end joint welding. Consult Thorburn for details. 2. Each hose assembly is pressure tested with demineralized water 1.5 X design pressure. 3. Use of Thorburn’s flexible metal hose assemblies should be undertaken only after thorough engineering analysis, prototyping and approval by end user.

(N)B95 Bronze Annular



Thorburn's (N)B96 Braided bronze hose is designed to provide protection from galvanic corrosion. It is manufactured from first-class bronze strip which contains less zinc content. Available in unbraided, single braided or double braided, it is ideal for use in moderate pressures and temperatures applications in copper pipe systems and a wide variety of industrial HVAC applications. Available with copper sweat and threaded connectors.

Hose Materials

UNS C19400/ASTM B465 (Sizes 1/4" to 2")

UNS C51900 ASTM B103 (Sizes 2 1/2" and above)

Bronze Hose with Bronze Braid

(N)B95 - Unbraided inner core **0**

(N)B96 - Braided hose **1**

(N)B96Z - Double braided hose **2**

Test Pressure: 1.5 X design pressure

Construction

- Medium wall butt welded tubing
- Standard pitch annular corrugations
- 4 to 1 safety factor over working pressures

Canadian Registration: Available upon request (All Provinces)

Nominal ID		Hose Type Code	Hose OD		Bend Radius				Live Length for Vibration		Working Pressure		Weight	
mm	in		mm	in	Static Bend		Constant Flexing		mm	in	bar	psi	kg/m	lbs/ft
6	1/4	0	12.5	0.49	50	2.0	152	6.0	100	4.0	6.89	100	0.022	0.13
		1	14.5	0.57							71.3	1035	0.031	0.23
		2	16.5	0.65							144.2	1656	0.045	0.33
9.5	3/8	0	15.5	0.61	50	2.0	152	6.0	152	6.0	4.13	60	0.022	0.16
		1	17.0	0.67							48.5	704	0.040	0.29
		2	18.5	0.73							64.5	936	0.058	0.42
12.7	1/2	0	19.3	0.76	58	2.3	178	7.0	152	6.0	3.44	50	0.031	0.23
		1	20.6	0.81							39.0	566	0.052	0.38
		2	22.1	0.87							51.9	753	0.073	0.53
19	3/4	0	26.7	1.05	64	2.5	203	8.0	178	7.0	2.06	30	0.045	0.33
		1	27.9	1.10							32.2	468	0.076	0.55
		2	29.5	1.16							42.8	622	0.106	0.77
25	1	0	34.0	1.34	76	3.0	229	9.0	203	8.0	1.79	26	0.056	0.41
		1	36.1	1.42							23.0	334	0.094	0.68
		2	38.0	1.50							30.6	444	0.131	0.95
31	1 1/4	0	42.2	1.66	89	3.5	254	10.0	229	9.0	1.10	16	0.098	0.71
		1	44.2	1.74							21.1	306	0.158	1.15
		2	46.2	1.82							28.1	407	0.219	1.59
40	1 1/2	0	48.0	1.89	100	4.0	254	10.0	229	9.0	1.03	15	0.128	0.93
		1	49.8	1.96							20.4	297	0.203	1.47
		2	51.6	2.03							27.2	395	0.277	2.01
50	2	0	63.0	2.48	152	6.0	279	11.0	254	10.0	0.68	10	0.138	1.00
		1	65.3	2.57							14.4	210	0.223	1.62
		2	67.6	2.66							19.2	279	0.309	2.24
63.5	2 1/2	0	84.6	3.33	215	8.5	406	16.0	279	11.0	0.55	8	0.235	1.70
		1	87.6	3.45							13.3	194	0.370	2.68
		2	90.7	3.57							17.7	258	0.506	3.66
80	3	0	98.8	3.89	254	10.0	508	20.0	279	11.0	0.34	5	0.290	2.10
		1	101.9	4.01							11.4	166	0.456	3.30
		2	104.9	4.13							15.2	221	0.622	4.50

Notes: 1. Suffix (N) is used with CRN. Pressures may be different than shown depending on method of fitting to end joint welding. Consult Thorburn for details. 2. Each hose assembly is pressure tested with demineralized water 1.5 X design pressure. 3. Use of Thorburn's flexible metal hose assemblies should be undertaken only after thorough engineering analysis, prototyping and approval by end user.

(N)S65 Extra Flex Helical



Type 321 Hose with SS304 Braid

- 0 - S65 Unbraided inner core
- 1 - S66 Braided hose
- 2 - S66Z Double braided hose

Type 316L Hose with SS304 Braid

- 0 - S61 Unbraided inner core
- 1 - S62 Braided hose
- 2 - S62Z Double braided hose

Applications

- Compressed gas
- Steel making
- Food processing
- Clean-in-place
- Automatic lubrication
- Self-draining fluid lines

Construction

- Medium wall spiral wound butt welded tubing
- Standard pitch helical corrugations
- 4 to 1 safety factor over working pressures

Thorburn's Extra-Flex is a spirally-welded corrugated hose specifically designed to achieve maximum flexibility with high pressure ratings. This unique hose features self-draining convolutions with minimal line turbulence characteristics. Thorburn's Extra-Flex is used when temperature extremes, corrosive media, or where permeation preclude the use of rubber, PTFE, or plastic hose.

Nominal ID		Hose Type	Hose OD		Bend Radius				Live Length for Vibration		Design Pressure		Weight	
					Static Bend		Constant Flexing				bar	psi	kg/m	lbs/ft
mm	in	Code	mm	in	mm	in	mm	in	mm	in	bar	psi	kg/m	lbs/ft
6	1/4	0	9.9	0.39	10.2	0.4	55.9	2.2	101.6	4	4.9	71	0.13	0.09
		1	11.4	0.45							122.4	1775	0.19	0.13
		2	13.0	0.51							171.3	2485	0.28	0.19
10	3/8	0	14.0	0.55	15.2	0.6	71.1	2.8	152.4	6	2.4	35	0.16	0.11
		1	15.5	0.61							78.3	1136	0.28	0.19
		2	17.0	0.67							117.5	1704	0.42	0.28
12.7	1/2	0	17.0	0.67	20.3	0.8	78.7	3.1	152.4	6	1.9	28	0.21	0.14
		1	18.5	0.73							62.6	908	0.39	0.26
		2	20.1	0.79							97.9	1420	0.58	0.39
19	3/4	0	25.9	1.02	35.6	1.4	129.5	5.1	177.8	7	1.0	14	0.33	0.22
		1	27.4	1.08							49.0	710	0.57	0.38
		2	30.0	1.18							78.3	1136	0.82	0.55
25	1	0	31.0	1.22	45.7	1.8	160.0	6.3	177.8	7	0.8	11	0.36	0.24
		1	32.5	1.28							39.2	568	0.80	0.54
		2	34.0	1.34							62.6	908	1.24	0.83
32	1 1/4	0	39.9	1.57	61.0	2.4	200.7	7.9	203.2	8	0.6	8	0.67	0.45
		1	41.9	1.65							31.3	454	1.13	0.76
		2	43.9	1.73							710	1.62	1.09	
40	1 1/2	0	48.0	1.89	76.2	3.0	238.8	9.4	203.2	8	0.5	7	0.97	0.65
		1	50.0	1.97							24.5	355	1.52	1.02
		2	52.1	2.05							39.2	568	2.08	1.40
51	2	0	59.9	2.36	88.9	3.5	279.4	11.0	228.6	9	0.3	5	1.06	0.71
		1	62.0	2.44							19.6	284	1.82	1.22
		2	64.0	2.52							31.3	454	2.60	1.75

Notes: 1. Suffix (N) is used with CRN. Pressures may be different than shown depending on method of fitting to end joint welding. Consult Thorburn for details. 2. Each hose assembly is pressure tested with demineralized water 1.5 X design pressure. 3. Use of Thorburn's flexible metal hose assemblies should be undertaken only after thorough engineering analysis, prototyping and approval by end user.

(N)S81 High Pressure Stainless Steel Annular



Type 316L Hose with SS304 Braid

- (N)S81 - Unbraided inner core 0
- (N)S82 - Braided hose 1
- (N)S82Z - Double braided hose 2

Test Pressure: 1.5 X design pressure

Construction

- Heavy wall butt welded tubing
- Closed pitch annular corrugations
- 4 to 1 safety factor over working pressures

Canadian Registration: Available upon request (All Provinces)

Nominal ID		Hose Type Code	Hose OD		Bend Radius				Live Length for Vibration		Working Pressure		Weight	
mm	in		mm	in	Static Bend		Constant Flexing		mm	in	bar	psi	kg/m	lbs/ft
6	1/4	0	12.7	0.50	63.5	2.50	127.0	5.00	101.6	4	12.4	180	0.13	0.09
		1	14.5	0.57							176.6	2562	0.25	0.17
		2	16.3	0.64							282.6	4099	0.39	0.26
10	3/8	0	17.0	0.67	69.9	2.75	139.7	5.50	127.0	5	6.9	100	0.19	0.13
		1	18.8	0.74							103.5	1501	0.37	0.25
		2	20.6	0.81							165.5	2401	0.54	0.36
12.7	1/2	0	20.8	0.82	38.1	1.50	203.2	8.00	152.4	6	5.5	80	0.58	0.39
		1	23.4	0.92							163.1	2365	0.93	0.63
		2	25.9	1.02							260.8	3783	0.98	0.67
19	3/4	0	30.7	1.21	50.8	2.00	203.2	8.00	152.4	6	4.8	70	0.71	0.48
		1	33.3	1.31							95.1	1379	1.18	0.79
		2	35.8	1.41							152.1	2206	1.64	1.10
25	1	0	38.1	1.50	76.2	3.00	228.6	9.00	203.2	8	2.8	40	1.18	0.79
		1	40.6	1.60							77.9	1130	1.79	1.20
		2	43.2	1.70							124.7	1808	2.40	1.61
32	1 1/4	0	47.0	1.85	82.6	3.25	254.0	10.00	203.2	8	2.3	33	1.52	1.02
		1	50.0	1.97							76.5	1110	2.41	1.62
		2	53.3	2.10							122.5	1776	3.30	2.22
40	1 1/2	0	55.1	2.17	82.6	3.25	254.0	10.00	228.6	9	1.4	20	2.02	1.36
		1	58.4	2.30							65.8	955	3.14	2.11
		2	61.7	2.43							105.4	1529	4.26	2.86
51	2	0	63.8	2.51	136.7	5.38	292.1	11.50	254.0	10	1.0	15	2.38	1.60
		1	67.1	2.64							55.8	810	3.66	2.46
		2	69.9	2.75							70.1	1017	4.94	3.32
63.5	2 1/2	0	82.0	3.23	177.8	7.00	609.6	24.00	254.0	10	0.7	10	2.98	2.00
		1	85.1	3.36							34.7	504	4.24	2.85
		2	88.6	3.49							55.6	806	4.91	3.30
80	3	0	96.0	3.78	190.5	7.50	711.2	28.00	279.4	11	0.7	10	4.42	2.97
		1	99.3	3.91							37.2	540	6.49	4.36
		2	102.4	4.03							44.8	650	8.56	5.75
100	4	0	122.2	4.81	508.0	20.00	1016.0	40.00	279.4	11	0.6	8	5.22	3.51
		1	125.2	4.93							19.7	286	5.98	4.02
		2	128.3	5.05							31.6	458	9.42	6.33
150	6	0	174.5	6.87	609.6	24.00	2413.0	95.00	279.4	11	0.3	5	5.16	3.47
		1	180.3	7.10							18.3	266	9.47	6.37
		2	186.2	7.33							29.3	425	13.35	8.97

Notes: 1. Suffix (N) is used with CRN. Pressures may be different than shown depending on method of fitting to end joint welding. Consult Thorburn for details. 2. Each hose assembly is pressure tested with demineralized water 1.5 X design pressure. 3. Use of Thorburn's flexible metal hose assemblies should be undertaken only after thorough engineering analysis, prototyping and approval by end user.

(N)S98Z Ultra High Pressure Fully Compressed Annular



Type 316L Hose with SS304 Braid
(N)S98Z - Ultra High Pressure Hose

Test Pressure: 1.5 X design pressure

Applications:

- Cryogenic truck loading & unloading
- Filling & sampling cryogenic storage dewers
- Cylinder filling of hydrogen, helium & natural gas
- Co2 & hydrogen gas systems

Construction

- Heavy wall butt welded tubing
- Closed pitch annular corrugations
- 4 to 1 safety factor over working pressures

Canadian Registration: Available upon request
(All Provinces)

Air separation technology is widely used in producing high purity gases such as oxygen, nitrogen, argon and rare gasses (neon and krypton). Thorburn S98Z metallic hose assemblies provide practical solutions to transfer high pressure gasses and cryogenic liquids.



Nominal ID		Hose Type Code	Braids #	Hose OD		Minimum Bend Radius				Live Length for Vibration		Design Pressure		Weight	
mm	in			mm	in	Static Bend		Constant Flexing		mm	in	bar	psi	kg/m	lbs/ft
6	1/4	B	2	17.3	0.68	152.4	6.00	304.8	12.00	101.6	4	413.7	6000	0.73	0.49
10	3/8	B	2	23.4	0.92	152.4	6.00	304.8	12.00	152.4	6	344.7	5000	1.15	0.77
12.7	1/2	B	2	24.9	0.98	177.8	7.00	355.6	14.00	152.4	6	310.3	4500	1.26	0.85
19	3/4	B	2	35.6	1.40	190.5	7.50	381.0	10.00	177.8	7	289.6	4200	2.35	1.58
25	1	B	3	48.8	1.92	203.2	8.00	406.4	16.00	203.2	8	248.2	3600	3.35	2.25
32	1 1/4	B	3	54.1	2.13	228.6	9.00	457.2	14.00	203.2	8	206.8	3000	5.52	3.71
40	1 1/2	B	3	59.9	2.36	241.3	9.50	482.6	13.00	203.2	8	151.7	2200	5.31	3.57
51	2	B	3	78.0	3.07	304.8	20.00	609.6	40.00	254.0	10	150.3	2180	3.42	2.30
80	3	B	3	107.2	4.22	812.8	32.00	2133.6	84.00	304.8	12	103.4	1500	12.95	8.70
100	4	B	4	133.9	5.27	1320.8	52.00	2844.8	112.00	304.8	12	86.2	1250	15.60	10.48

Notes: 1. Suffix (N) is used with CRN. Pressures may be different than shown depending on method of fitting to end joint welding. Consult Thorburn for details. 2. Each hose assembly is pressure tested with demineralized water 1.5 X design pressure. 3. Use of Thorburn's flexible metal hose assemblies should be undertaken only after thorough engineering analysis, prototyping and approval by end user.

(N)S99Z High Pressure Fully Compressed Annular



Thorburn Model (N)S99Z nuclear hose assemblies routinely have a protective FJ72 Fry-Sil jacket cover to facilitate handling and provide protection against wear

(N)S99Z Series

Thorburn’s high pressure (N)S99Z metallic high pressure hose assemblies were specifically designed to transfer heavy water in a fuel handling system found in a CANDU 6 nuclear power generating station. The corrugations are fully compressed to support high pressure applications. Flexible wire braid is used as an axial restraint, vibration dampener and provides columnar stability against squirm. The hose is capable of being twisted 90° over its entire length and can withstand an annual radiation dose of 1X10⁷ rads combined gamma and neutron radiation. Thorburn’s (N)S99Z can be manufactured to meet the design requirements of ASME Section III and CSA N285.0 components and has been successfully registered for service in a PHWR nuclear power plant in a variety of applications.

(N)S99Z Nuclear CRN Examples

- ½” NFD-3-5889.5
- ¾” NFD-3-4348.5
- 1” NFD-3-3961.5R2

Construction

- Heavy wall butt welded tubing
- 4 to 1 safety factor over working pressures
- Closed pitch annular fully compressed corrugations
- SA240 type 321 multiple layered braid
A580 type SS304

Applications

- High pressure flow injection flexible connectors
- Fuelling machine head catenary D₂O transfer

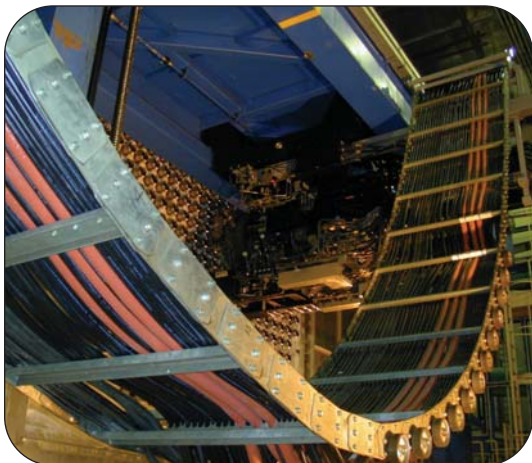
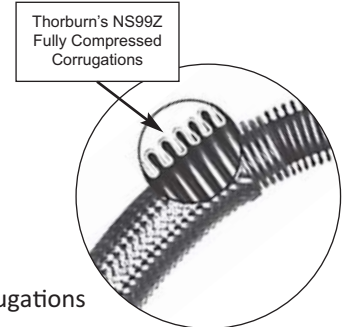

Thorburn Model (N)S99Z nuclear hose assemblies with Thorburn’s FJ72 Fry-Sil jacket cover (orange) installed in CANDU catenary D₂O transfer system

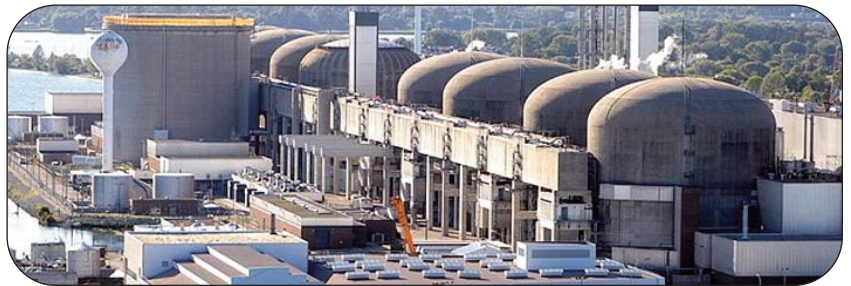

Thorburn Model (N)S99Z nuclear hose assemblies have been installed in all CANDU reactors worldwide

(N)S99Z Series

Nominal ID		Hose Type Code	Hose OD		Bend Radius				Live Length for Vibration		Design Pressure		Weight	
mm	in		mm	in	Static Bend		Constant Flexing		mm	in	bar	psi	kg/m	lbs/ft
12.7	1/2	2	25.9	1.02	177.8	7.00	355.6	14.00	152.4	6	241.3	3500	1.43	0.96
19	3/4	2	37.1	1.46	190.5	7.50	381.0	15.00	177.8	7	186.2	2700	2.07	1.39
25	1	2	45.0	1.77	203.2	8.00	406.4	16.00	177.8	7	178.2	2585	3.15	2.12

Notes: 1. Suffix (N) is used with CRN. Pressures may be different than shown depending on method of fitting to end joint welding. Consult Thorburn for details. 2. Each hose assembly is pressure tested with demineralized water 1.5 X design pressure. 3. Use of Thorburn’s flexible metal hose assemblies should be undertaken only after thorough engineering analysis, prototyping and approval by end user.

(N)S50HD Ultra High Pressure Compressed Helical



Type 321 Hose with 321 Braid (N)S50HD - Ultra High Pressure Hose

Note: Other materials available upon request

Test Pressure: 1.5 X design pressure

Construction

- Extra Heavy wall butt welded tubing
- Closed pitch Helical Omega-shaped corrugations
- 4 to 1 safety factor over working pressures

Canadian Registration: Available upon request (All Provinces)

Applications

Thorburn's S50HD Ultra-high pressure metallic hose assemblies are designed for extreme pressure applications that require flexible seal to absorb movements at temperatures outside the limits of rubber hose assemblies. Typical applications for Thorburn's S50HD hose assemblies are found in sub sea and surface well head oil Christmas tree piping systems. Oil well Christmas trees are used in surface and sub sea wells to control the flow, usually oil or gas out of the well. Thorburn's S50HD hose assembly provides the flexible element to absorb vibration and lateral movement in the Christmas tree piping system.



Surface oil well Christmas tree

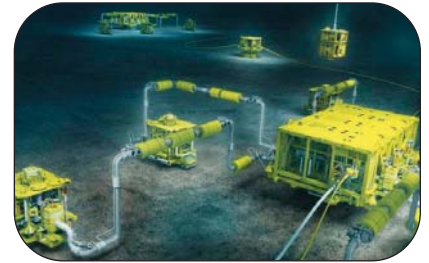

Sub sea oil well Christmas tree

Nominal ID		Braids	Hose OD		Minimum Bend Radius				Live Length for Vibration		Design Pressure		Weight	
mm	in		mm	in	Static Bend		Constant Flexing		mm	in	bar	psi	kg/m	lbs/ft
6	1/4	3	17.3	0.68	64	2.5	292	11.5	152	6	827.4	12000	0.92	0.62
10	3/8	3	22.9	0.90	95	3.8	381	15.0	178	7	620.5	9000	1.44	0.97
12.7	1/2	3	26.4	1.04	114	4.5	419	16.5	203	8	586.1	8500	1.99	1.34
19	3/4	3	38.6	1.52	165	6.5	775	30.5	229	9	468.8	6800	3.81	2.56
25	1	3	49.0	1.93	229	9.0	889	35.0	254	10	430.9	6250	5.49	3.69
32	1 1/4	3	54.6	2.15	254	10.0	965	38.0	305	12	379.2	5500	7.56	5.08
40	1 1/2	4	64.5	2.54	305	12.0	1041	41.0	356	14	358.5	5200	9.87	6.63
51	2	4	77.2	3.04	381	15.0	1219	48.0	457	18	299.9	4350	12.01	8.07
80	3	4	103.1	4.06	635	25.0	1651	65.0	610	24	206.8	3000	22.04	14.81

Notes: 1. Suffix (N) is used with CRN. Pressures may be different than shown depending on method of fitting to end joint welding. Consult Thorburn for details. 2. Each hose assembly is pressure tested with demineralized water 1.5 X design pressure. 3. Use of Thorburn's flexible metal hose assemblies should be undertaken only after thorough engineering analysis, prototyping and approval by end user.

(N)S69 Annular Closed Pitch Omega



Thorburn's model (N)S69 metallic hose is made with true omega corrugations which minimizes stress points when flexing. The thicker wall provides longer service life at increased pressure ratings. Thorburn's model (N)S69 meets ISO 10380 50,000 cycle test.

Type 321 Hose with SS304 Braid

- (N)S69 Braided hose **1**
- (N)S69Z Double braided hose **2**
- (N)S69Y Triple braided hose **3**

Construction

- Medium wall butt welded tubing
- Closed pitch omega annular corrugations
- 4 to 1 safety factor over working pressures

Applications

- High pressure impulse cycling

Thorburn's NS69 Omega type corrugations

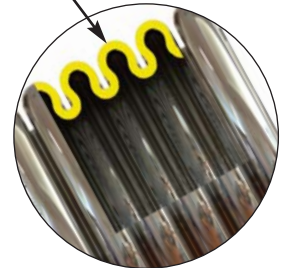

Nominal ID		Hose Type Code	Hose OD		Bend Radius				Live Length for Vibration		Design Pressure		Weight	
mm	in		mm	in	Static Bend		Constant Flexing		mm	in	bar	psi	kg/m	lbs/ft
10	3/8	1	17.1	0.67	76.2	3.0	152.4	6	127.0	5	181.0	2625	0.46	0.31
		2	18.5	0.73	101.6	4.0	203.2	8			224.1	3250	0.76	0.51
		3	20.6	0.81	127.0	5.0	254.0	10			249.9	3625	0.90	0.60
12.7	1/2	1	21.1	0.83	114.3	4.5	190.5	7.5	152.4	6	137.9	2000	0.58	0.39
		2	22.6	0.89	152.4	6.0	254.0	10			220.6	3200	0.94	0.63
		3	25.0	1.00	177.8	7.0	304.8	12			240.0	3480	1.22	1.82
19	3/4	1	29.5	1.16	152.4	6.0	228.6	9	152.4	6	108.6	1575	0.88	0.59
		2	32.0	1.26	203.2	8.0	304.8	12			181.0	2625	1.43	0.96
		3	35.2	1.39	228.6	9.0	355.6	14			240.0	3480	1.89	1.27
25	1	1	36.3	1.43	171.5	6.75	266.7	10.5	203.2	8	94.8	1375	1.09	0.73
		2	39.1	1.54	228.6	9.0	355.6	14			141.3	2050	1.64	1.10
		3	41.5	1.63	254.0	10.0	406.4	16			170.0	2465	2.24	1.51
32	1 1/4	1	47.5	1.87	114.3	7.0	342.9	13.5	203.2	8	77.6	1125	1.96	1.32
		2	50.3	1.98	152.4	7.5	457.2	18			124.1	1800	3.01	2.02
		3	51.5	2.03	203.2	8.0	508.0	20			222.0	3220	3.68	2.47
40	1 1/2	1	55.6	2.19	133.4	7.5	419.1	16.5	228.6	9	70.7	1025	2.32	1.56
		2	57.2	2.25	177.8	8.0	558.8	22			120.7	1750	3.79	2.55
		3	56.5	2.22	228.6	9.0	609.6	24			114.9	1667	4.85	3.26
51	2	1	67.3	2.65	171.5	8.5	457.2	18	254.0	10	58.6	850	2.87	1.93
		2	70.6	2.78	228.6	9.5	609.6	24			91.4	1325	4.67	3.14
		3	72.5	2.85	279.4	11.0	660.4	26			100.0	1450	6.75	4.54
64	2 1/2	1	86.9	3.42	190.5	9.0	495.3	19.5	254.0	10	43.1	625	4.05	2.72
		2	89.7	3.53	254.0	10.0	660.4	26			77.6	1125	6.29	4.23
		3	92.5	3.64	304.8	12.0	711.2	28			93.1	1350		
76	3	1	101.1	3.98	285.8	11.5	609.6	24	279.4	11	38.8	563	4.76	3.20
		2	103.9	4.09	381.0	15.0	812.8	32			68.9	1000	7.02	4.72
		3	106.7	4.20	431.8	17.0	863.6	34			86.2	1250		
102	4	1	125.0	4.92	381.0	15.0	762.0	30	279.4	11	25.0	363	5.64	3.79
		2	127.8	5.03	508.0	20.0	1016.0	40			43.1	625	8.16	5.48
		3	130.6	5.14	609.6	24.0	1066.8	42			53.4	775		

Notes: 1. Suffix (N) is used with CRN. Pressures may be different than shown depending on method of fitting to end joint welding. Consult Thorburn for details. 2. Each hose assembly is pressure tested with demineralized water 1.5 X design pressure. 3. Use of Thorburn's flexible metal hose assemblies should be undertaken only after thorough engineering analysis, prototyping and approval by end user.

LS Series - Lock Section



LS Series (Unpacked)



Thorburn's "LS" series is an "S" lock section hose that is primarily designed for conveying air, exhaust and dry bulk products. A single interlocking strip of metal is spirally wound to form a durable, standard bore flexible hose.

LS Series (Packed)



Thorburn's "LS" series hose can be supplied packed consisting of a continuous strand inserted into the groove of the hose during manufacturing. The strand is sealed inside the hose for additional leak proofing and will not contaminate the media during transfer.

Applications

- Engine exhaust
- Ventilation ducts
- Fume extracting
- Auto heating tubing
- Hot air ducting
- Protective casing
- Dust collecting
- Conveying grain or sawdust

Tar-Flex Tar & Asphalt Hose Assemblies Series TFS & TFS4

Thorburn's Tar-Flex hose has uniform flexibility for ease of handling and excellent resistance to deterioration by heat. The ruggedness and dependability of a fully interlocked and packed construction, makes Thorburn's Tar-Flex the ideal hose for road surfacing service, asphalt carrying truck use, road patching units, hot tar pots and kettles and hand held patching hoses.

Applications

- Tank car loading
- High pressure steam
- Engine exhaust
- Oil & liquid transfer
- Asphalt tanks

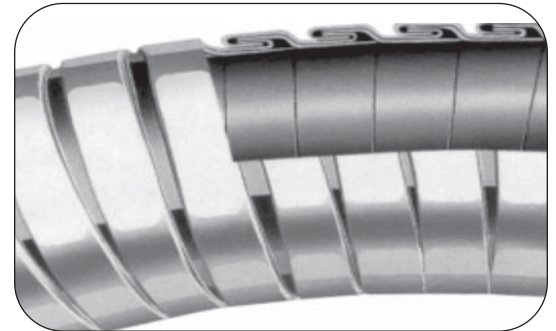

Specifications

TFS - Galvanized steel
(.020" to .060" metal)
TFS4 - 304SS
(.017" to .040" metal)

Packing Type	Benefits	Temperature Ability
Cotton	Lowest cost	180°F
Pyro-Pak	Coated high temperature filament	1000°F
Hard Packing (Copper, SS)	For extreme high temperatures	1200°F
Elastomeric	Max. pressure/vacuum resistance	180°F

LS Series Part Numbers

Thickness	Unpacked	Elastomeric Packed	Pyro-Pak Packed	Cotton Packed	Copper Wire Stainless	
					Packed	Wire Packed
Light Weight (0.10" - 0.12")	LS12	LS12E	LS12A	LS12B	LS12C	LS12S
Medium Weight (0.13" - 0.16")	LS16	LS16E	LS16A	LS16B	LS16C	LS16S
Medium-Heavy Weight (0.17" - 0.20")	LS20	LS20E	LS20A	LS20B	LS20C	LS20S
Heavy Weight (0.21" - 0.22")	LS24	LS24E	LS24A	LS24B	LS24C	LS24S
Extreme Heavy Weight (0.23" - 0.30")	LS32	LS32E	LS32A	LS32B	LS32C	LS32S

Size	ID (in)	OD (in)					Minimum Inside Bend Radius (in)					Approximate Weight (lbs/ft)				
		LS12	LS16	LS20	LS24	LS32	LS12	LS16	LS20	LS24	LS32	LS12	LS16	LS20	LS24	LS32
08	1/2	5/8	11/16				3.5	4.0				0.14	0.16			
10	5/8	3/4	13/16				4.0	4.5				0.17	0.22			
12	3/4	7/8	15/16				4.5	5.0				0.20	0.26			
14	7/8	1	1 1/16				5.5	6.0				0.25	0.33			
16	1	1 1/8	1 3/16	1 1/4			6.5	7.0	7.5			0.26	0.35	0.50		
18	1 1/8	1 1/4	1 5/16	1 3/8			7.0	7.5	8.0			0.30	0.39	0.60		
20	1 1/4	1 3/8	1 7/16	1 1/2			7.5	8.5	9.0			0.32	0.42	0.64		
22	1 3/8	1 1/2	1 9/16	1 5/8			8.0	9.0	10.0			0.36	0.47	0.70		
24	1 1/2	1 5/8	1 11/16	1 3/4			8.5	10.0	11.0			0.40	0.52	0.85		
28	1 3/4	1 7/8	1 15/16	2			10.0	11.0	11.5			0.45	0.66	0.95		
32	2	2 1/8	2 3/16	2 1/4	2 9/32	2 5/16	11.5	12.5	13.0	15.0	17.0	0.66	0.78	1.15	1.45	1.71
36	2 1/4	2 3/8	2 7/16	2 1/2	2 17/32	2 9/16	13.0	14.0	15.0	17.0	18.0	0.70	0.91	1.29	1.63	1.92
40	2 1/2	2 5/8	2 11/16	2 3/4	2 25/32	2 13/16	15.0	16.0	17.0	19.5	20.0	0.80	1.04	1.44	1.81	2.14
44	2 3/4	2 7/8	2 15/16	3	3 1/32	3 1/16	17.0	18.0	19.0	22.0	23.0	0.92	1.12	1.58	1.99	2.35
48	3	3 1/8	3 3/16	3 1/4	3 9/32	3 5/16	19.0	19.5	21.0	24.0	26.0	1.02	1.33	1.73	2.18	2.56
56	3 1/2	3 5/8	3 11/16	3 3/4	3 25/32	3 13/16	22.0	23.5	25.0	26.0	27.0	1.26	1.64	2.01	2.54	2.99
64	4	4 1/8	4 3/16	4 1/4	4 9/32	4 5/16	24.0	25.5	27.0	28.5	30.0	1.38	1.80	2.30	2.90	3.42
72	4 1/2	4 5/8	4 11/16	4 3/4	4 25/32	4 13/16	27.0	28.5	30.0	31.0	33.0	1.55	2.02	2.59	3.26	3.85
80	5	5 1/8	5 3/16	5 1/4	5 9/32	5 5/16	29.0	31.0	33.0	34.0	36.0	1.70	2.21	2.86	3.63	4.28
96	6	6 1/8	6 3/16	6 1/4	6 5/32	6 5/16	38.0	40.5	43.0	45.0	47.0	2.00	2.60	3.45	4.35	5.13
112	7	7 1/8	7 3/16	7 1/4	7 9/32	7 5/16	45.0	46.0	48.0	50.0	52.0	2.30	3.00	4.03	5.08	5.99
128	8	8 1/8	8 3/16	8 1/4	8 9/32	8 5/16	48.0	51.0	55.0	57.0	59.0	2.60	3.38	4.60	5.80	6.84
144	9	9 1/8	9 3/16	9 1/4	9 9/32	9 5/16	52.0	56.0	59.0	61.0	63.0	3.10	4.03	5.18	6.53	7.70
160	10	10 1/8	10 3/16	10 1/4	10 9/32	10 5/16	56.0	60.0	63.0	66.0	69.0	3.50	4.35	5.75	7.25	8.55
192	12		12 3/16	12 1/4	12 9/32	12 5/16		70.0	75.0	78.0	80.0		5.46	6.90	8.70	10.25
224	14			14 1/4	14 9/32	14 5/16			85.0	88.0	95.0			6.05	10.15	11.95

AF Series - Ball Joint Armor-Flex™ Hose Guard



Thorburn's Armor-Flex™ Hose Guard (Cover) will not restrict bending

Thorburn's Ball Joint Armor-Flex™ is different than standard interlock hose in that there is no interlocking parts to restrict hose bending. Armour-Flex is made from concave & convex sections that roll off each other when the hose is bending. It can be used as an outer shield for both metallic and elastomeric hoses. Combined with insulation, Armor-Flex™ can operate in environments up to 1100°C and provides protection against molten splash and abrasion.

Advantages

- Will not restrict bending
- Unlimited flex life & kink resistant
- Minimum force to flex
- Available in steel & stainless steel

Material Codes: AF = Carbon Steel
AFS4 = 304SS
AFS6 = 316SS



Thorburn's Ball Joint Armor-Flex™ tested at 1100°C

SFM Series - Smooth-Flex

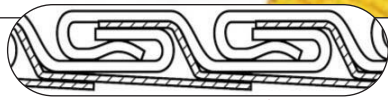

FLOW →

Bulk materials flow smoothly in one direction only

Interlock hose with smooth liner inside

Thorburn Series SFM combines a single strip interlocking construction with a smooth liner, providing a flexible metal hose that resists material build-up and internal abrasion.

Designed for Pneumatic & Gravity Feeding or bulk materials

- Grains
- Dry food stuffs
- Wood chips
- Plastic pellets
- Saw dust
- Suction lines
- Powders
- Flue ducts
- Ashes
- Aluminum chips
- Charcoal

Applications

- Ships
- Barges
- Trucks
- Rail cars
- Elevators
- Tanks
- Silos
- In-plant
- Great for portable applications



Smooth-Flex SFM-S6 Hose with a Welded Female Camlock End



Dry bulk material railcar loading systems

Type		All Stainless			Steel / Stainless Steel (CS)			Steel / Steel (CC)		
		Heavy Duty SFM500(X)	Medium Duty SFM400(X)	Light Duty SFM300(X)	Heavy Duty SFM350S	Medium Duty SFM250S	Light Duty SFM150S	Heavy Duty SFM350C	Medium Duty SFM250C	Light Duty SFM150C
Armor Material		Type 304, 316 Stainless Steel			Hot Dip Galvanized Coated Carbon Steel					
Armor Thickness (in)		0.18	0.18	0.15	0.18	0.18	0.15	0.18	0.18	0.15
Liner Material		Type 304, 316 Stainless Steel			Type 301 Stainless Steel			Hi-Carbon Steel		
Liner Thickness		0.18	0.15	0.15	0.18	0.18	0.15	0.18	0.18	0.15
Extension-Compression percent of length		± 1 %	± 1 1/2 %	± 2 %	± 1 %	± 1 1/2 %	± 2 %	± 1 %	± 1 1/2 %	± 2 %
Temp. & Pressure Ratings	GT Packing	-20°F to 180°F (neg. 5°Hg, pos. 20 psi)			-20°F to 180°F (neg. 5°Hg, pos. 20 psi)					
	AP Packing	-40°F to 400°F (neg. 5°Hg, pos. 20 psi)			-40°F to 400°F (neg. 20°Hg, pos. 20 psi)					
	CC Packing	-60°F to 300°F (neg. 15°Hg, pos. 15 psi)			-60°F to 300°F (neg. 15°Hg, pos. 15 psi)					
	SS Packing	-60°F to 1500°F (neg. 15°Hg, pos. 15 psi)			-60°F to 400°F (neg. 15°Hg, pos. 15 psi)					
	Unpacked	-60°F to 1500°F (No Pressure Rating)			-60°F to 400°F (No Pressure Rating)					

Material Code: Replace (X) with S4 for 304SS and S6 for 316SS

FJ72 Fry-Sil Fire Jacket

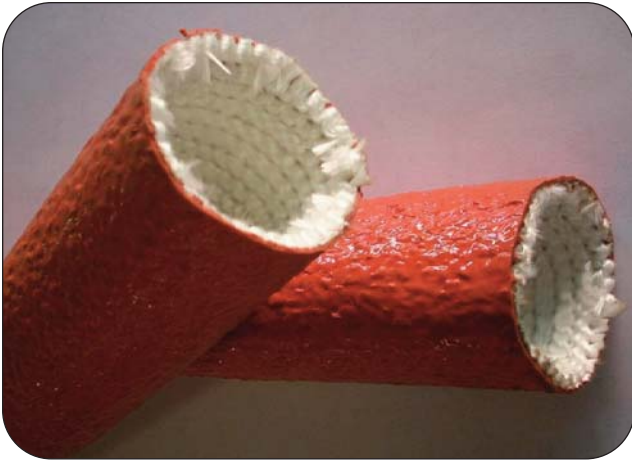

Thorburn's FJ72 Fry-Sil fire Jacket is made from woven fiberglass insulation and 100% iron oxide silicone rubber. The sleeve can withstand continuous exposure to 500° F (260°C); up to 2000°F (1090°C) for 15-20 minutes; and up to 3000°F (1650°C) for 15-30 seconds. Thorburn's FJ72 Fry-Sil fire jackets slip on easily and expands over fittings and connectors.

Features

- Oil & water resistant
- Can be shaped to fit the tightest bends
- Perfect for insulating oil & fuel lines
- Protects against dirt & grime
- Withstands up to 1650°C ambient heat
- Withstands up to 260°C continuous heat

Low cost protection against production interruptions & personal injuries

- Withstands intermittent flame
- Protects against molten spatter
- Prevents slag and resin build up
- Protects against abrasion & corrosion
- Protects operators from hot metal hoses & pipes
- "Danger Red" color provides a strong visual warning
- Skin & respirator irritations caused by fiberglass are minimized by the red silicone rubber cover

Size Code	Inside Dia (mm)	Inside Dia (Inch)
04	6	1/4
05	8	5/16
06	10	3/8
07	11	7/16
08	13	1/2
10	16	5/8
12	19	3/4
14	22	7/8
16	25	1
18	29	1 1/8
20	32	1 1/4
22	35	1 3/8
24	38	1 1/2
25	40	1 3/5
26	41	1 5/8
28	45	1 3/4
30	48	1 7/8
32	51	2

Size Code	Inside Dia (mm)	Inside Dia (Inch)
35	55	2 1/5
36	57	2 1/4
38	60	2 3/8
40	64	2 1/2
43	65	2 3/5
44	70	2 3/4
48	76	3
50	80	3 1/5
52	83	3 1/4
54	85	3 3/8
56	89	3 1/2
57	90	3 9/16
60	95	3 3/4
64	102	4
70	110	4 1/3
72	114	4 1/2
77	120	4 4/5
80	127	5

FJ73 Fry-Sil Tape



Thorburn's FJ73 Fry-Sil Fire Tape is used in situations where Thorburn's FJ72 Fry-Sil Fire Jacket cannot be installed such as when industrial hoses, wires and cables cannot be disconnected. Thorburn's FJ73 Fry-Sil Fire Tape protects industrial hydraulic hose, wires, cables, tube and pipe from exposure to extreme heat conditions. The silicone rubber material protects against molten metals, slag, welding splatter, electrical or grinding sparks and contamination.

How to Order Thorburn FJ72 Fry-Sil Fire Jacket

FJ72-16-25*

Part Number Description

FJ72 - FJ72 Fry-Sil Fire Jacket

16 - 1 inch ID

25 - feet in length

* Metric length - insert length in millimeters and add suffix mm

Example: **FJ72-16-7620mm** (25mm ID X 7620mm OAL)

For Hose ID size codes
see Page 28

How to Order Thorburn FJ73 Fry-Sil Tape

FJ73-16-25*

Part Number Description

FJ73 - FJ73 Fry-Sil Tape

16 - 1 inch width

25 - feet in length

* Metric length - insert length in millimeters and add suffix mm

Example: **FJ73-16-7620mm** (25mm ID X 7620mm OAL)

Nominal Widths Available

1" (25mm) - Code 16

2" (50mm) - Code 32

3" (80mm) - Code 48

Standard Fitting To End Joints

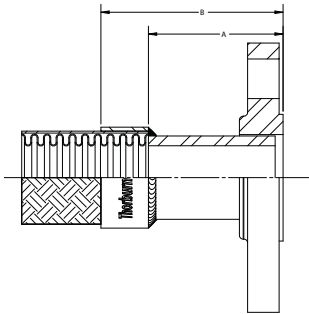

Raised Face Slip On Flange													
Class 150 LB (Forged RF) (inches)	Hose ID	1	1 1/4	1 1/2	2	2 1/2	3	4	6	8	10	12	
	A	11/16	13/16	7/8	1	1 1/8	1 3/16	1 5/16	1 9/16	1 3/4	1 15/16	2 3/16	
	B	1 7/16	1 9/16	1 7/8	2	2 1/8	2 3/16	2 9/16	2 13/16	3	3 3/16	3 7/16	
Class 300 LB (Forged RF) (inches)	Hose ID	1	1 1/4	1 1/2	2	2 1/2	3	4	6	8	10	12	
	A	1 1/16	1 1/16	1 3/16	1 5/16	1 1/2	1 11/16	1 7/8	2 1/16	2 7/16	2 5/8	2 7/8	
	B	1 13/16	1 13/16	2 3/16	2 5/16	2 1/2	2 11/16	3 1/8	3 5/16	3 11/16	3 7/8	4 1/8	
Common Materials		ASTM A-105 F STL, ASTM/ASME A/SA-182 T-304, T-316 Stainless Steel											

Note: Fitting to end joint minimal dimensions

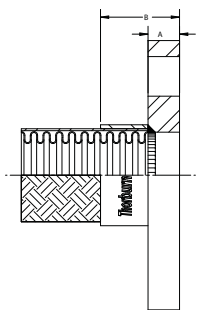

Flat Face Plate Flange													
Class 150 LB (inches)	Hose ID	1	1 1/4	1 1/2	2	2 1/2	3	4	6	8	10	12	
	A	5/8	3/4	13/16	15/16	1 1/16	1 1/8	1 1/4	1 1/2	1 11/16	1 7/8	2 1/8	
	B	1 3/8	1 1/2	1 13/16	1 15/16	2 1/16	2 1/8	2 1/2	2 3/4	2 15/16	3 1/8	3 3/8	
Class 300 LB (inches)	Hose ID	1	1 1/4	1 1/2	2	2 1/2	3	4	6	8	10	12	
	A	1	1	1 1/8	1 1/4	1 7/16	1 5/8	1 13/16	2	2 3/8	2 1/2	2 3/4	
	B	1 3/4	1 3/4	2 1/8	2 1/4	2 7/16	2 5/8	3 1/16	3 1/4	3 3/4	3 13/16	4 1/16	
DIN PN10 (Plate FF) (mm)	Hose ID (DIN)	25	32	40	50	65	80	100	150	200	250	300	
	A	16	18	18	20	20	20	22	24	24	26	28	
	B	35	40	43	45	45	45	54	56	56	58	60	
DIN PN16 (Plate FF) (mm)	Hose ID (DIN)	25	32	40	50	65	80	100	150	200	250	300	
	A									26	29	32	
	B									58	61	64	
DIN PN25 (Plate FF) (mm)	Hose ID (DIN)	25	32	40	50	65	80	100	150	200	250	300	
	A							26	30	32	35	38	
	B							58	62	64	67	70	
Common Materials		ASTM A/SA-516GR70, A/SA-36 Carbon Steel, ASTM/ASME A/SA-240 T-304, T-316 Stainless Steel											

Note: Fitting to end joint minimal dimensions

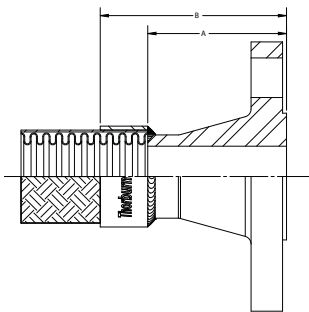

Raised Face Weld Neck Flange													
Class 150 LB (Forged RF) (inches)	Hose ID	1	1 1/4	1 1/2	2	2 1/2	3	4	6	8	10	12	
	A	2 3/16	2 1/4	2 7/16	2 1/2	2 3/4	2 3/4	3	3 1/2	4	4	4 1/2	
	B	2 15/16	3	3 7/16	3 1/2	3 3/4	3 3/4	4 1/4	4 3/4	5 1/4	5 1/4	5 3/4	
Class 300 LB (Forged RF) (inches)	Hose ID	1	1 1/4	1 1/2	2	2 1/2	3	4	6	8	10	12	
	A	2 7/16	2 9/16	2 11/16	2 3/4	3	3 1/8	3 3/8	3 7/8	4 3/8	4 3/8	5 1/8	
	B	3 3/16	3 5/16	3 11/16	3 3/4	4	4 1/8	4 5/8	5 1/8	5 5/8	5 7/8	6 3/8	
Common Materials		ASTM A-105 F STL, ASTM/ASME A/SA-182 T-304, T-316 Stainless Steel											

Note: Fitting to end joint minimal dimensions

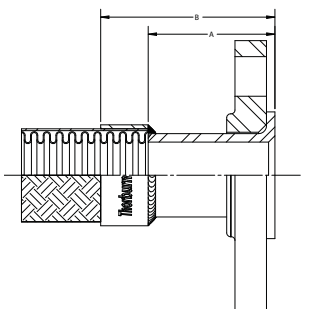

Lap Joint Swivel (Floating) Flange With Type A Short Stub End													
Class 150 LB (Forged RF) (inches)	Hose ID	1	1 1/4	1 1/2	2	2 1/2	3	4	6	8	10	12	
	A	2	2	2	2 1/2	2 1/2	2 1/2	3	3 1/2	4	5	6	
	B	2 3/4	2 3/4	3	3 1/2	3 1/2	3 1/2	4 1/4	4 3/4	5 1/4	6 1/4	7 1/4	
Class 300 LB (Forged RF) (inches)	Hose ID	1	1 1/4	1 1/2	2	2 1/2	3	4	6	8	10	12	
	A	2 3/8	2 1/4	2 5/16	2 13/16	2 7/8	3	3 9/16	4	4 5/16	6 13/16	7 13/16	
	B	2 15/16	2 7/8	3 5/16	3 13/16	3 7/8	4	4 13/16	5 1/4	5 9/16	8 1/16	9 1/16	
Common Materials		Flanges: ASTM A-105 F STL, ASTM/ASME A/SA-182 T-304SS, T-316SS - Stub End: A/SA-403 T-304SS, T-316SS											

Note: Fitting to end joint minimal dimensions

Standard Fitting To End Joints

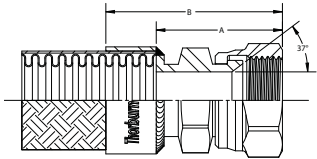

JIC Swivel Female (37° Flare) / BSPP Swivel											
Hose ID	1/4	3/8	1/2	3/4	1	1 1/4	1 1/2	2			
A	1 5/16	1 3/8	1 1/2	1 3/4	2	2 1/8	2 1/4	2 5/8			
B	1 11/16	1 7/8	2 1/8	2 1/2	2 3/4	3 7/8	3 1/4	3 5/8			
Common Materials	ASTM/ASME A/SA-105, ASTM/ASME A/SA-182/479 T-316SS										

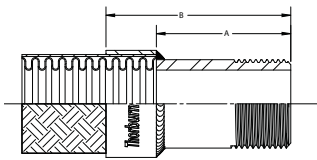

NPT / BSPT / BSPP Male Nipple											
Hose ID	1/4	3/8	1/2	3/4	1	1 1/4	1 1/2	2	2 1/2	3	4
A	1 1/2	1 1/2	1 3/4	2	2	2 1/2	2 1/2	2 1/2	3	3	4
B	1 7/8	1 7/8	2 3/8	2 5/8	2 5/8	3 1/4	3 1/4	3 1/2	4	4	5
Common Materials	ASTM/ASME A/SA-106, ASTM/ASME A/SA-312/479 T-316SS										

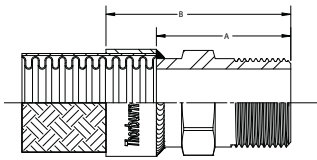

Hex Male NPT / BSPT / BSPP Male Nipple											
Hose ID	1/4	3/8	1/2	3/4	1	1 1/4	1 1/2	2	2 1/2	3	4
A	1 3/16	1 1/4	1 7/16	1 1/2	1 11/16	1 15/16	2 1/8	2 1/2	3	3	4
B	1 9/16	1 5/8	2 1/16	2 1/8	2 5/16	2 11/16	2 7/16	3 3/16	4	4	5
Common Materials	ASTM/ASME A/SA-105, ASTM/ASME A/SA-182/479 T-304SS & T-316SS										

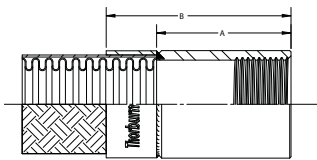

Female NPT / BSPT Half Coupling											
Hose ID	1/4	3/8	1/2	3/4	1	1 1/4	1 1/2	2	2 1/2	3	4
A	1 5/16	1 3/8	1 1/2	1 3/4	2	2 1/8	2 1/4	2 5/8	3 1/2	3 1/2	4 1/2
B	1 11/16	1 7/8	2 1/8	2 1/2	2 3/4	3 7/8	3 1/4	3 5/8	4 1/2	4 1/2	5 1/2
Common Materials	ASTM/ASME A/SA-105, ASTM/ASME A/SA-182/479 T-304SS & T-316SS										

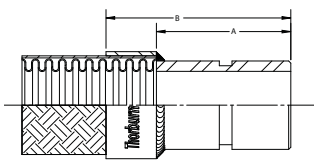

Grooved Pipe End (Victaulic)											
Hose ID	1	1 1/4	1 1/2	2	2 1/2	3	4	6	8	10	12
A	1 3/8	1 5/8	2	2 3/8	2 7/8	3 1/2	4 1/2	6 5/8	8 5/8	10 3/4	12 3/4
B	2 1/8	2 1/2	3	3 3/8	3 7/8	4 1/2	5 3/4	7 7/8	8 7/8	12	14
Common Materials	ASTM/ASME A/SA-106, ASTM/ASME A/SA-312/479 T-316SS, 304SS										

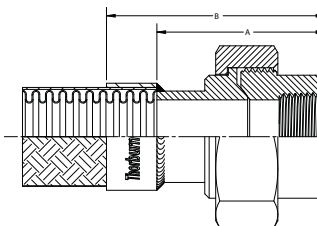

Female NPT Union - Class 150, 300											
Hose ID	1/4	3/8	1/2	3/4	1	1 1/4	1 1/2	2	2 1/2	3	4
A	1 11/16	1 3/16	1 15/16	1 15/16	2 1/4	2 3/8	2 5/8	3	3 1/2	4 1/8	4 3/8
B	2 1/16	2 3/16	2 9/16	2 9/16	2 7/8	3 1/8	3 3/8	4	4 1/2	5 1/8	5 5/8
Common Materials	Malleable Iron, T-304 & T-316, A/SA-312/479 T-316SS										

Female NPT & Socket Weld Unions - Class 3000 SP-83											
Hose ID	1/4	3/8	1/2	3/4	1	1 1/4	1 1/2	2	2 1/2	3	4
A	1 3/4	1 7/8	2	2 5/16	2 1/2	2 7/8	3 1/16	3 1/2	4 1/16	4 3/8	6 7/8
B	2 1/8	2 3/8	2 5/8	3 1/16	3 1/4	3 3/4	4 1/16	4 1/2	5 1/16	5 3/8	8 1/8
Common Materials	ASTM A-105 F STL, ASTM/ASME A/SA-182 T-304 & T-316 Stainless Steel										

Standard Fitting To End Joints

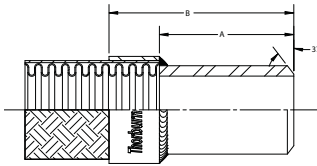

Welding Nipple 37 1/2 inch Bevel											
Hose ID	1/4	3/8	1/2	3/4	1	1 1/4	1 1/2	2	2 1/2	3	4
A	1 1/2	1 1/2	1 3/4	1 3/4	1 3/4	1 3/4	1 3/4	2 1/8	2 1/8	2 1/8	2 1/2
B	1 7/8	1 7/8	2 3/8	2 3/8	2 3/8	2 1/2	2 1/2	3 1/8	3 1/8	3 1/8	3 1/2
Common Materials	ASTM/ASME A/SA-106, ASTM/ASME A/SA-312/479 T-316SS										

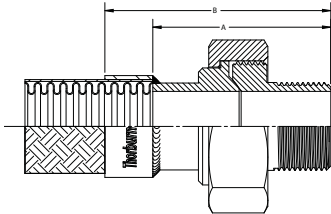

Male Union											
Hose ID	1/4	3/8	1/2	3/4	1	1 1/4	1 1/2	2	2 1/2	3	4
A	2 1/4	2 1/2	2 11/16	3 1/8	3 3/8	3 3/4	3 5/16	4 5/16	5 1/16	5 1/2	
B	2 5/8	3 1/8	3 5/16	3 3/4	4	4 1/2	4	5 5/16	6 1/16	6 1/2	
Common Materials	ASTM A-105 F STL, ASTM/ASME A/SA-182/479 T-304 & T-316 Stainless Steel										

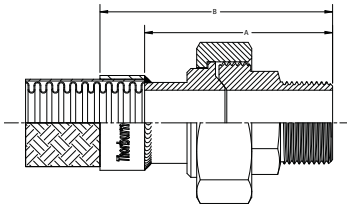

Hex Male Union											
Hose ID	1/4	3/8	1/2	3/4	1	1 1/4	1 1/2	2	2 1/2	3	4
A	2 9/16	2 3/4	3	3 5/16	3 15/16	4 5/16	4 5/16	4 9/16	5 5/16	5 13/16	
B	2 5/16	3 1/8	3 1/2	4 1/4	4 9/16	5 1/16	5 3/8	5 5/8	6 3/8	6 7/8	
Common Materials	ASTM A-105 F STL, ASTM/ASME A/SA-182/479 T-304 & T-316 Stainless Steel										

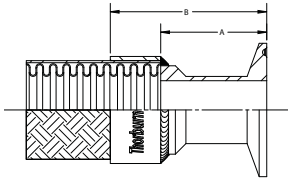

Sanitary Flange											
Hose ID	1/4	3/8	1/2	3/4	1	1 1/4	1 1/2	2	2 1/2	3	4
A			2	2	2	2 1/2	2 1/2	3 1/2	3 1/2	3 1/2	4
B			3	3	3	3 1/2	3 1/2	4 1/2	4 1/2	4 1/2	5 1/4
Common Materials	ASTM/ASME A/SA-182/479 T-304 & T-316 Stainless Steel										

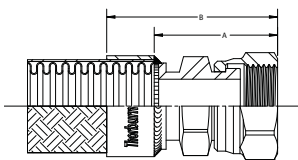

O-Ring Face Seal/Fittings Female Swivel											
Hose ID	1/4	3/8	1/2	3/4	1	1 1/4	1 1/2	2	2 1/2	3	4
A	1 11/16	1 3/16	1 15/16	1 15/16	2 1/4	2 3/8	2 5/8	3	3 1/2	4 1/8	
B	2 1/16	2 3/16	2 9/16	2 9/16	2 7/8	3 1/8	3 3/8	4	4 1/2	5 1/8	
Common Materials	ASTM A-105 F STL, ASTM/ASME A/SA-182/479 T-304 & T-316 Stainless Steel										

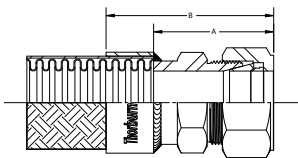

Swagelok Compatible Tube Fitting											
Hose ID	1/4	3/8	1/2	3/4	1						
A	1 5/8	1 7/8	1 7/8	2 1/4	2 3/4						
B	2	2 3/8	2 1/2	3	3 1/2						
Common Materials	ASTM A-105 F STL, ASTM/ASME A/SA-182/479 T-304 & T-316 Stainless Steel										

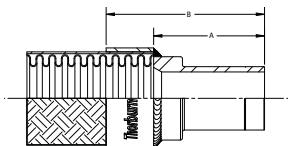

Swagelok Compatible Tube End											
Tube ID	1/4	3/8	3/8 X 1/2*	1/2	3/4	3/4 X 1*	1 X 3/4*	1			
A	1 3/8	1 1/2	2	1 7/8	2 1/4	2 3/4	3	3 1/4			
B	1 3/4	2	2 1/2	2 1/2	3	3 1/2	3 3/4	4			
Common Materials	ASTM A-105 F STL, ASTM/ASME A/SA-182/479 T-304 & T-316 Stainless Steel										

* Step up or step down tube OD size

Standard Fitting To End Joints

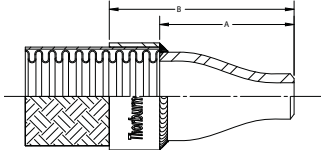

Concentric Reducer										
Hose ID X Pipe	3/4X3/8	3/4X1/2	1X3/8	1X1/2	1X3/4	1 1/4X1/2	1 1/4X3/4	1 1/4X1	1 1/2X1/2	1 1/2X3/4
A	1 1/2	1 1/2	2	2	2	2	2	2	2 1/2	2 1/2
B	2	2	2 3/4	2 3/4	2 3/4	2 7/8	2 7/8	2 7/8	3 1/2	3 1/2
Hose ID	1 1/2X1	1 1/2X1 1/4	2X3/4	2X1	2X1 1/4	2X1 1/2	2 1/2X1	2 1/2X1 1/4	2 1/2X1 1/2	2 1/2X2
A	2 1/2	2 1/2	3	3	3	3	3 1/2	3 1/2	3 1/2	3 1/2
B	3 1/2	3 1/2	4	4	4	4	4 1/2	4 1/2	4 1/2	4 1/2
Hose ID	3X1	3X1 1/4	3X1 1/2	3X2	3X2 1/2	3 1/2X1 1/4	3 1/2X1 1/2	3 1/2X2	3 1/2X2 1/2	3 1/2X3
A	3 1/2	3 1/2	3 1/2	3 1/2	3 1/2	4	4	4	4	4
B	4 1/2	4 1/2	4 1/2	4 1/2	4 1/2	5	5	5	5	5
Hose ID	4X1 1/2	4X2	4X2 1/2	4X3	4X3 1/2	5X2 1/2	5X3	5X4	6X2 1/2	6X3
A	4	4	4	4	4	5	5	5	5 1/2	5 1/2
B	5 1/4	5 1/4	5 1/4	5 1/4	5 1/4	6 1/4	6 1/4	6 1/4	6 3/4	6 3/4
Hose ID	6X4	6X5	8X4	8X5	8X6	10X4	10X6	10X8	12X8	12X10
A	5 1/2	5 1/2	6	6	6	7	7	7	8	8
B	6 3/4	6 3/4	7 1/4	7 1/4	7 1/4	8 1/4	8 1/4	8 1/4	9 1/4	9 1/4
Common Materials	ASTM/ASME A/SA-234WPB Carbon Steel, A/SA 403 T-304 & T-316 Stainless Steel									

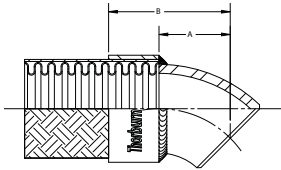

Long Radius 45° Elbow										
Hose ID	1/2	3/4	1	1 1/4	1 1/2	2	2 1/2	3	4	6
A	5/8	3/4	7/8	1	1 1/8	1 3/8	1 3/4	2	2 1/2	3 3/4
B	1 1/4	1 1/2	1 5/8	1 3/4	2 1/8	2 3/8	2 3/4	3	3 3/4	5
Common Materials	ASTM/ASME A/SA-234WPB Carbon Steel, A/SA 403 T-304 & T-316 Stainless Steel									

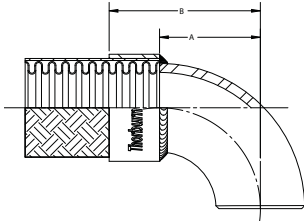

Long Radius 90° Elbow										
Hose ID	1/2	3/4	1	1 1/4	1 1/2	2	2 1/2	3	4	6
A	1 1/2	1 1/2	1 1/2	1 7/8	2 1/4	3	3 3/4	4 1/2	6	9
B	2 1/8	2 1/4	2 1/4	2 3/4	3 1/4	4	4 3/4	5 1/2	7 1/4	10 1/4
Common Materials	ASTM A-105 F STL, ASTM/ASME A/SA-182 T-304 & T-316 Stainless Steel									

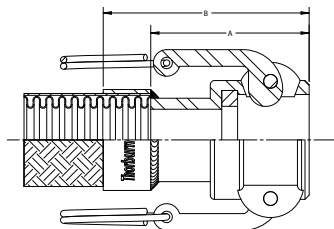

Female Camlock Type "C" Coupling (2 Cams)										
Hose ID	1/2	3/4	1	1 1/4	1 1/2	2	2 1/2	3	4	6
A	2 1/2	2 1/2	3	3 1/4	3 1/2	4	4 1/4	4 1/2	4 3/4	6 1/2
B	3 1/8	3 1/4	3 3/4	4 1/8	4 1/2	5	5 1/4	5 1/2	6	7 3/4
Common Materials	SA351 CF8M/SA479 T316 Stainless Steel									

• Specify Gasket Material BUNA N (Standard) Options: EPDM (Code H), FKM (Code I), PTFE Encapsulated Rubber (Code ER)

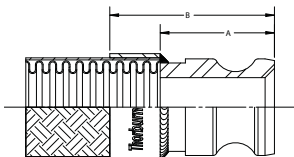

Male Camlock Type "E" Coupling										
Hose ID	1/2	3/4	1	1 1/4	1 1/2	2	2 1/2	3	4	6
A	3	3	3 1/2	4	4	4 1/2	5	5 1/4	5 1/2	7 1/4
B	3 5/8	3 3/4	4 1/2	4 7/8	5	5 1/2	6	6 1/4	6 3/4	8 1/2
Common Materials	SA351 CF8M/SA479 T316 Stainless Steel									

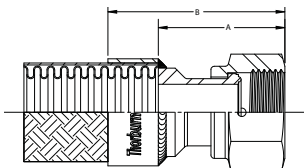

Metal Gasket Face Seal Female Swivel (Swagelok VCR Compatible)										
Hose ID	1/4	3/8	1/2	3/4	1					
A	1 5/8	1 3/4	1 7/8	2	2 2/4					
B	2	2 1/4	2 1/2	2 3/4	3 1/2					
Common Materials	ASTM/ASME A/SA-182 T-304 & T-316 Stainless Steel									

How to Order Thorburn Corrugated Metal Hose Assemblies

Hose Type	1st End	2nd End	Hose Size	Length in Inches	Cover	Liner																																																													
NS96	06	06	32	64*	TS	LAF																																																													
<p>(N)S61 (N)S62 (N)S62Z (N)S65 (N)S66 (N)S66Z (N)S69 (N)S69Z (N)S69Y (N)S81 (N)S82 (N)S82Z (N)S95 (N)S96 (N)S96Z (N)B95 (N)B96 (N)B96Z (N)S91 (N)S92 (N)S92Z (N)S93 (N)S93Z (N)H95 (N)H96 (N)H96Z (N)HS95 (N)HS96 (N)HS96Z (N)I95 (N)I96 (N)I96Z (N)IS95 (N)IS96 (N)IS96Z (N)M95 (N)M96 (N)M96Z (N)S98Z NS99Z (N)S50HD</p> <p>Special Assemblies (N)S40 TJHS TJHD TJHC</p>	<p style="text-align: center;">End Fittings</p> <p>01 - Male nipple carbon steel 02 - Male nipple 304SS 03 - Male nipple 316SS 04 - Hex male carbon steel 05 - Hex male 304SS 06 - Hex male 316SS 07 - Female union carbon steel 150# 07X - Female union CS JIC w/adaptor 08 - Female union 304SS 150# 09 - Female union 316SS 150# 09X - Female union-316SS JIC w/adaptor 10 - Female 37° 304SS 11 - Solid female pipe carbon steel 12 - Solid female pipe 304SS 13 - Solid female pipe 316SS 14 - Weld nipple carbon steel 15 - Weld nipple 304SS 16 - Weld nipple 316SS 17 - Fixed flange carbon steel 150# 18 - Fixed flange 304SS 150# 19 - Fixed flange 316SS 150# 20 - Weld neck flange carbon steel 150# 21 - Weld neck flange 304SS 150# 22 - Weld neck flange 316SS 150# 23 - Lap joint flange 150# CS 24 - Lap joint flange 150# & stub end 304SS 25 - Lap joint flange 150# & stub end 316SS 26 - Lap jnt flange 150# CS & stub end 304SS 27 - Lap jnt flange 150# CS & stub end 316SS 28 - 3000# male union - carbon steel 29 - 3000# male union - 304SS 30 - 3000# male union - 316SS 31 - Male union - 316SS JIC w/adaptor 32 - Female union carbon steel 3000# 33 - Female union 304SS 3000# 34 - Female union 316SS 3000# 35 - 150# CS male union 36 - Female 37° carbon steel 37 - Female JIC 37° 316 stainless steel 38 - Victaulic carbon steel 39 - Victaulic 304SS 40 - Victaulic groove 316SS 41 - Sanitary Flange 316SS 42 - Male union - CS JIC w/adaptor 43 - Copper Sweat 44 - Male NPT Brass 45 - Female NPT Brass 60 - Met-O-Seal female* 61 - Met-O-Seal male* 62 - Met-O-Seal socket weld* 63 - Camlock male shank E 316SS 64 - Camlock female coupler C 316SS 65 - Camlock elbow* 66 - Camlock male elbow* 67 - Tank truck male adapter* 68 - 4 Cam female coupler C-HD 316SS 69 - Tube end* 70 - Pre-swaged nut & double sleeve* 71 - Pre-welded "O" seal gland and nut* 72 - Metal gasket face seal female swivel* XX - Specify end type and material YY - Specify end type and material</p> <p>* Specify Material under assembly part number</p>	<table border="1"> <thead> <tr> <th>Code</th> <th>in</th> <th>DN</th> </tr> </thead> <tbody> <tr><td>04</td><td>1/4</td><td>6</td></tr> <tr><td>05</td><td>5/16</td><td>8</td></tr> <tr><td>06</td><td>3/8</td><td>10</td></tr> <tr><td>08</td><td>1/2</td><td>12</td></tr> <tr><td>10</td><td>5/8</td><td>16</td></tr> <tr><td>12</td><td>3/4</td><td>20</td></tr> <tr><td>16</td><td>1</td><td>26</td></tr> <tr><td>20</td><td>1 1/4</td><td>30</td></tr> <tr><td>24</td><td>1 1/2</td><td>40</td></tr> <tr><td>32</td><td>2</td><td>50</td></tr> <tr><td>40</td><td>2 1/2</td><td>65</td></tr> <tr><td>48</td><td>3</td><td>80</td></tr> <tr><td>56</td><td>3 1/2</td><td>95</td></tr> <tr><td>64</td><td>4</td><td>100</td></tr> <tr><td>80</td><td>5</td><td>125</td></tr> <tr><td>96</td><td>6</td><td>150</td></tr> <tr><td>128</td><td>8</td><td>200</td></tr> <tr><td>160</td><td>10</td><td>250</td></tr> <tr><td>192</td><td>12</td><td>300</td></tr> </tbody> </table>	Code	in	DN	04	1/4	6	05	5/16	8	06	3/8	10	08	1/2	12	10	5/8	16	12	3/4	20	16	1	26	20	1 1/4	30	24	1 1/2	40	32	2	50	40	2 1/2	65	48	3	80	56	3 1/2	95	64	4	100	80	5	125	96	6	150	128	8	200	160	10	250	192	12	300	<p>Assembly length in inches including decimals</p> <p>* For metric length, put m for meters, mm for millimeters (rounded up or down with no decimals) after number</p> <p>Example: 64.75" or 1625mm or 12m</p>	<p>Cover Codes Blank if N/A</p> <p>Insulation Cover FJ = Fry-Sil Jacket TS = Thor-Sil SFS = Saturated Fiberglass Sleeving UCS = Ceramic Sleeving Unsaturated CT = Cryo-Therm</p> <p>Protective Covers AF = Armor Flex CLS12(X) = Lock Section CLS16(X) = Lock Section CLS20(X) = Lock Section CLS24(X) = Lock Section CLS32(X) = Lock Section</p> <p>(X) = Add suffix S4 = 304SS S6 = 316SS</p> <p>Carbon Steel = Leave Blank</p>	<p>Lock Section Hose LS12 (X) (Y) LS16 (X) (Y) LS20 (X) (Y) LS24 (X) (Y) LS32 (X) (Y) SFM500 (X) (Y) SFM400 (X) (Y) SFM300 (X) (Y) SFM350C (X) SFM250C (X) SFM150C (X)</p> <p>(X)=Packing Codes Blank=Unpacked E=Elastomeric A=Pyro-pak B=Cotton C=Copper S=SS (Y)=Material Codes Blank=Steel S4=304SS S6=316SS</p>	<p>Ordering Metric, Forged & Different Flange Class Ends</p> <p>To order 300# flange, 600# flange, etc., use 150# assembly part number add suffix (300#) or (600#) after part code.</p> <p>To order forged slip on raised face flanges A105 or A182 ANSI B16.5 Class 150, 300, 600, etc., please add "A" after the flange for class 150 add code ie: 17A, 18A, 19A. Forged 300 and forged 600 flanges add 17A(300), 18A(300), 19A(300), 17A(600), 18A(600), 19A(600). use same logic for weld neck and lap joint flanges.</p> <p>To order PN10, PN16, PN25 flanges, please use the 150# flange part code and add suffix (PN10), (PN16), (PN25) code ie: 17(PN10), 18PN10, 19(PN10). Use the same logic for PN16 & PN25 and carry on the same logic for weld neck and lap joint flanges.</p> <p style="text-align: center;">Ordering Ends Other Materials</p> <p>To order ends with materials other than shown on fitting codes, please add prefix M - Monel, H - Hastelloy & I - Inconel i.e. M1 - Monel male nipple, H20 - Hastelloy Fixed flange 150#, I16 - Inconel Weld nipple</p> <p>Special notes for material grades & schedules: 1. For material grades such as Inconel 625, Inconel 800HT, Hastelloy C276 etc. please indicate grade under part number. 2. Male & weld nipples, specify schedule under part number</p>	<p>Liner Codes Blank if N/A</p> <p>Protective Liners LAF = Armor Flex LLS12(X) = Lock Section LLS16(X) = Lock Section LLS20(X) = Lock Section LLS24(X) = Lock Section LLS32(X) = Lock Section</p> <p>(X) = Add suffix S4 = 304SS S6 = 316SS</p> <p>Carbon Steel = Leave Blank</p>
Code	in	DN																																																																	
04	1/4	6																																																																	
05	5/16	8																																																																	
06	3/8	10																																																																	
08	1/2	12																																																																	
10	5/8	16																																																																	
12	3/4	20																																																																	
16	1	26																																																																	
20	1 1/4	30																																																																	
24	1 1/2	40																																																																	
32	2	50																																																																	
40	2 1/2	65																																																																	
48	3	80																																																																	
56	3 1/2	95																																																																	
64	4	100																																																																	
80	5	125																																																																	
96	6	150																																																																	
128	8	200																																																																	
160	10	250																																																																	
192	12	300																																																																	

(N)S40 Series - Oxy lance™ Oxygen Lance Hose Assemblies



Basic Oxygen Furnace (BOF)



Thorburn's Oxy lance™ hose assemblies are installed in a 180° bend

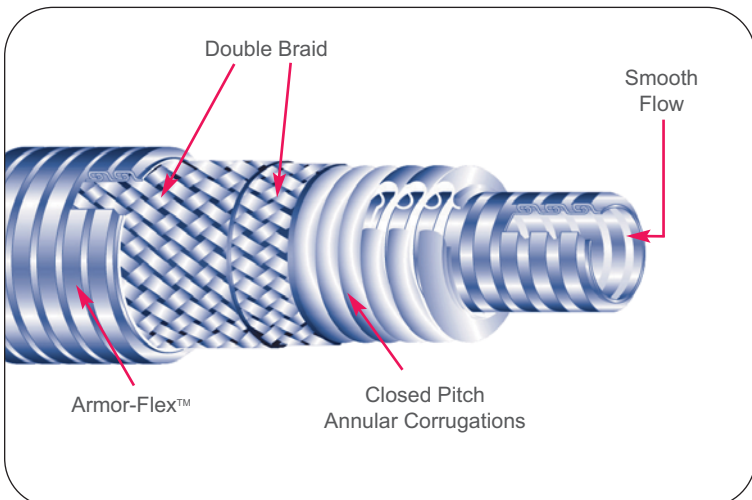

Metallic oxygen lance hose cross-section

Thorburn's Oxy lance™ Series (N)S40 - Oxygen Lance Hose
During steel production, the raw iron is converted into steel inside a Basic Oxygen Furnace (BOF). Oxygen is blown into the furnace via a water cooled lance. Oxygen lances are large, multiwall tubes which deliver oxygen to the BOF. Cooling water and oxygen are fed by hose assemblies to the lance. The lance is moved up and down to adjust its distance from the molten steel bath.

Thorburn manufactures metallic oxygen lance hose assemblies for the critical transfer of oxygen to the basic oxygen furnace (BOF). Designed to accommodate the required movements while providing temperature resistance up to 815°C without deterioration, zero leakage and complete oxygen compatibility. Thorburn's Oxy lance™ Series (N)S40 includes an inner integrated flow liner to reduce pressure loss and turbulent flow resulting from high velocity oxygen and an external flexible shield to protect the braid from abrasion. All components coming in contact with the oxygen are made of stainless steel and free from oil and grease.

Features

- Full size range of product from 1/4" to 12" inner diameter
- Internal liner to protect the hose from turbulence and high velocities seen in oxygen lances
- External guard to shield the assembly from molten slag and high ambient temperatures
- Machine-braided hose for the best fit and braid coverage
- ASME certified welders ensures highest quality fabrication
- Highly flexible hose simplifies shipping packaging

Applications

- Withstands external combustion
- Leak proof under pressure & vacuum service
- Withstands temperatures up to 815°C
- Cleaned & degreased for oxygen transfer service
- Smooth flow, reduces pressure loss
- No age hardening, no shelf life limitations
- Longer cycle life than a rubber hose assembly

Ordering

To order Thorburn Oxy lance™ (N)S40 Hose assemblies, please refer to Page 28

Cryogenic Carbon Dioxide Connectors



Thorburn, a leader in the manufacture of flexible metal and teflon hose assemblies, is proud to add to its products—stainless steel and brass loading and unloading adapters for the air separation industry. Thorburn stocks tanker connectors for oxygen, nitrogen and argon loading/unloading. In addition, Thorburn offers hose ends, trailer and customer connections for CO₂ and gaseous hydrogen. All Thorburn connectors and fittings conform to CGA standards for complete compatibility.

Carbon Dioxide Brass Connectors

Thorburn's high quality brass connections for CO₂ hoses include bull nose, nut, client/tanker end, safety dust plugs and dust caps. All Thorburn connectors are precision machined to CGA standards.



Cryogenic Unloading Hose Assemblies



Thorburn's CAD/CAM technology has dramatically increased productivity and simplified the introduction of conceptual ideas into finished products.



Compressed Gas Bulk Loading Station

Thorburn offers the compressed gas industries the broadest range of hose assemblies to better meet each gas special requirements. Thorburn's CGA96 hose assemblies are especially used to transfer, Carbon Dioxide (CO₂), Oxygen (O₂), Argon Ag, Nitrogen (N₂), Helium (He) and Hydrogen (H₂). Thorburn's models CGH66 helical lined cryogenic hose assemblies have been specifically designed to reduce the effects of snowballing during CO₂ transfer service.

Advantages

- Safe and reliable cryogenic liquid transfer
- Maximum operating pressure 400psi (27.6 bar)
- Operating temperature -452°F (-269°C) to 1000°F (538°C)
- Fully compliant with CGA V6

Metallic Hose Assemblies | Special Purpose Hose Assemblies

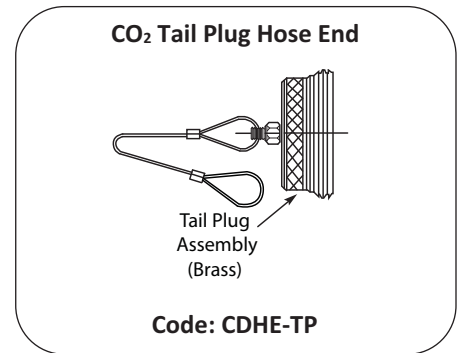
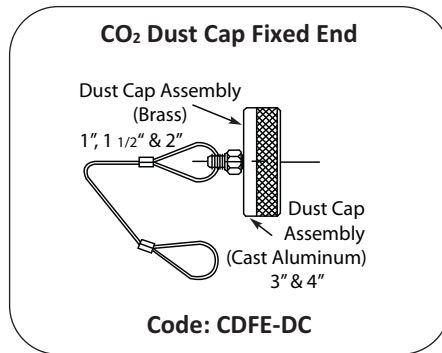
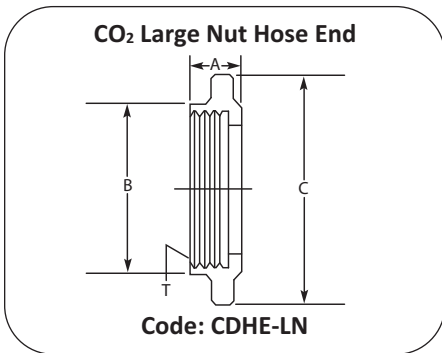
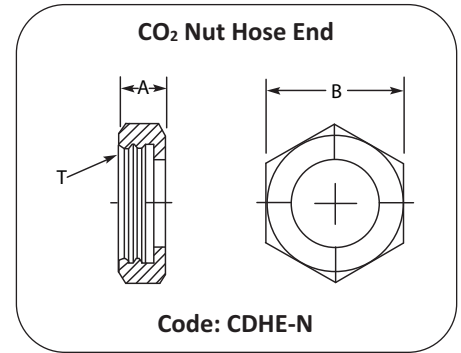
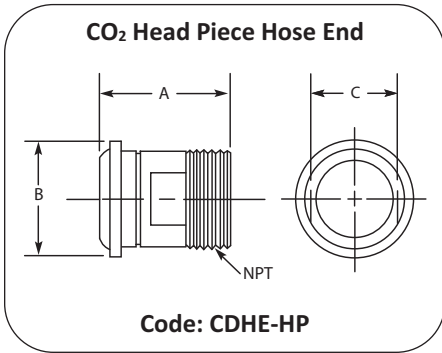
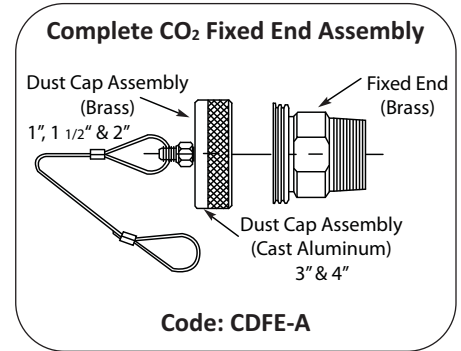
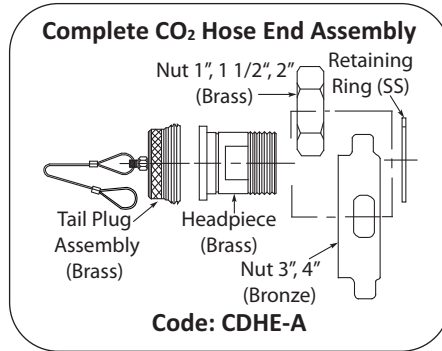

How To Order Thorburn CGA Carbon Dioxide Connectors

Size	NPT (in)	Thread Size	Hose End				Fixed End		
			Assembly	Head Piece	Nut	Tail Plug	Complete Assembly	Head Piece	Dust Cap
1" (25mm)	1 - 11 1/2	1 11/16 - 6ACME	16 CDHE-A	16 CDHE-HP	16 CDHE-N	16 CDHE-TP	16 CDFE-A	16 CDFE-HP	16 CDFE-DC
1 1/2" (38mm)	1 1/2 - 11 1/2	2 1/4 - 6ACME	24 CDHE-A	24 CDHE-HP	24 CDHE-N	24 CDHE-TP	24 CDFE-A	24 CDFE-HP	24 CDFE-DC
2" (50mm)	2 - 11 1/2	3 3/16 - 6ACME	32 CDHE-A	32 CDHE-HP	32 CDHE-N	32 CDHE-TP	32 CDFE-A	32 CDFE-HP	32 CDFE-DC
3" (80mm)	3 - 11 1/2	4 1/2 - 6ACME	48 CDHE-A	48 CDHE-HP	48 CDHE-N	48 CDHE-TP	48 CDFE-A	48 CDFE-HP	48 CDFE-DC
4" (100mm)	4 - 11 1/2	5 1/2 - 6ACME	64 CDHE-A	64 CDHE-HP	64 CDHE-N	64 CDHE-TP	64 CDFE-A	64 CDFE-HP	64 CDFE-DC

Material: 1" (25mm) & 1 1/2" (38mm) sizes - Forged Brass per ASTM B-283 | 2" (50mm), 3" (80mm) & 4" (100mm) sizes - Brass Bar per ASTM B-16 | Hose Nut: 3" (80mm) Bronze ASTM B-584

Cryogenic Fittings - Nitrogen, Oxygen & Argon Liquid Transfer



Oxygen, Nitrogen, Argon, Stainless Steel Connectors

Thorburn manufactures cryogenic liquid (oxygen, nitrogen, argon) transfer hose assemblies. The end connectors are fully compliant with CGA V6 and are designed for safe, reliable cryogenic liquid transfer. Thorburn also offers rail car fixed end assemblies.

Complete Hose End Assembly

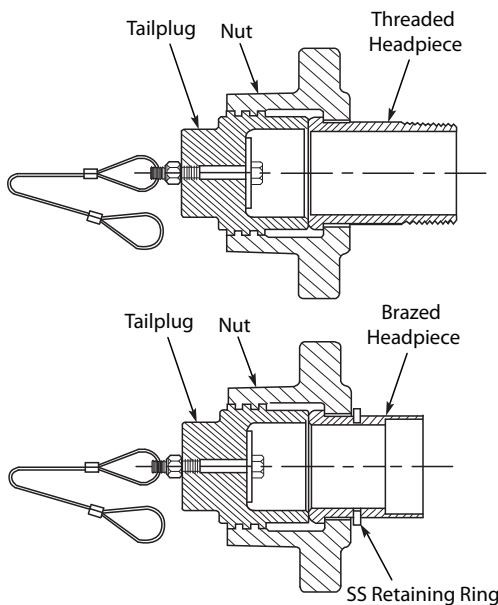

Thorburn Part #	Hose Size (in)	Fitting Size (in)	Liquid Service	CGA
24 CGA-NI-HE-TA 24 CGA-NI-HE-BA	1 1/2	1 1/2	Nitrogen	NI-150
40 CGA-NI-HE-TA 40 CGA-NI-HE-BA	2 1/2	2 1/2	Nitrogen	NI-250
32X40 CGA-NI-HE-TA 32X40 CGA-NI-HE-BA	2	2 1/2	Nitrogen	NI-250
24 CGA-AR-HE-TA 24 CGA-AR-HE-BA	1 1/2	1 1/2	Argon	AR-150
40 CGA-AR-HE-TA 40 CGA-AR-HE-BA	2 1/2	2 1/2	Argon	AR-250
32X40 CGA-AR-HE-TA 32X40 CGA-AR-HE-BA	2	2 1/2	Argon	AR-250
24 CGA-OX-HE-TA 24 CGA-OX-HE-BA	1 1/2	1 1/2	Oxygen	OX-150
32 CGA-OX-HE-TA 32 CGA-OX-HE-BA	2	2	Oxygen	OX-200
48 CGA-OX-HE-TA 48 CGA-OX-HE-BA	3	3	Oxygen	OX-300
48X32 CGA-OX-HE-TA 48X32 CGA-OX-HE-BA	3	2	Oxygen	OX-300

Note: All assembly numbers are for **Bronze nuts & Naval Brass Head pieces**.
Stainless Steel - order as individual pieces.
Insert suffix **S4** for 304SS material, **S6** for 316SS material. **Example:** 32X40 CGA-NI-HE-TA-S6

Head Piece Threaded

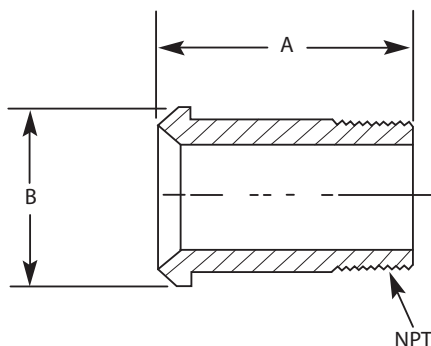

Thorburn Part #	Size (in)	NPT (in)	A (in)	B (in)
24 CGA-HE-HPT	1 1/2 Hose X 1 1/2 Nut	1 1/2 - 11 1/2	2.750	2.187
32 CGA-HE-HPT	2 Hose X 2 Nut	2 - 11 1/2	3.000	2.697
40 CGA-HE-HPT	2 1/2 Hose X 2 1/2" Nut	2 1/2 - 8	3.625	3.190
32X40 CGA-HE-HPT	2 Hose X 2 1/2" Nut	2 - 11 1/2	4.000	3.190
48X48 CGA-HE-HPT	3 Hose X 3 Nut	3 - 8	3.625	3.937
32X48 CGA-HE-HPT	2 Hose X 3 Nut	2 - 11 1/2	3.750	3.937
40x48 CGA-HE-HPT	2 1/2 Hose X 3 Nut	2 1/2 - 8	4.000	3.937

Material: Naval Brass per ASTM B-21. 316L/304 Stainless Steel per ASTM A-276
Precision machined to conform to **Compressed Gas Association** standards.

Metallic Hose Assemblies | Special Purpose Hose Assemblies

Hose Nut

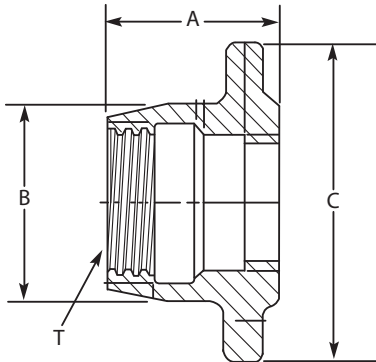

Thorburn Part #	Size (in)	CGA	Thread Size (in)	A (in)	B (in)	C (in)
24 CGA-NI-HE-N	1 1/2	NI-150	2.4 X 4 Stub ACME	2.812	3.250	5.250
40 CGA-NI-HE-N	2 1/2	NI-250	3.5 X 4 ACME	2.937	4.375	6.250
24 CGA-AR-HE-N	1 1/2	AR-150	2.7 X 4 Stub ACME	2.812	3.500	5.250
40 CGA-AR-HE-N	2 1/2	AR-250	3.813 X 4 Stub ACME	2.937	4.625	6.875
24 CGA-OX-HE-N	1 1/2	OX-150	2.5 X 4 ACME	2.125	3.250	5.000
32 CGA-OX-HE-N	2 1/2	OX-200	3 X 4 Stub ACME	2.062	3.500	6.000
48 CGA-OX-HE-N	3	OX-200	4.25 X 4 ACME	2.375	5.000	6.750

Material: Cast Bronze per ASTM B148-9D & ASME B505, 316L Stainless Steel per ASTM A-351, CF3M. Precision machined to conform to **Compressed Gas Association** standards for cryogenic liquid transfer connections. Insert suffix **S4** for 304SS material, **S6** for 316SS material. **Example:** 24 CGA-NI-HE-N-S6

Tail Plug Assembly

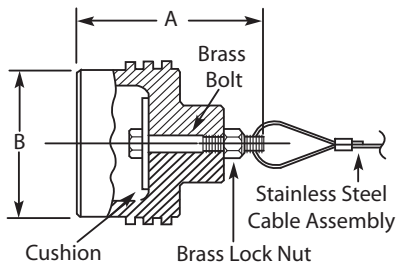

Thorburn Part #	Size (in)	Liquid Service	Thread Size (in)	A (in)	B (in)
24 CGA-NI-HE-TPTA	1 1/2	Nitrogen	2.4 X 4 Stub ACME	4	
40 CGA-NI-HE-TPTA	2 1/2	Nitrogen	3.5 X 4 ACME	4	
24 CGA-AR-HE-TPTA	1 1/2	Argon	2.7 X 4 Stub ACME	4	
40 CGA-AR-HE-TPTA	2 1/2	Argon	3.813 X 4 Stub ACME	4	
24 CGA-OX-HE-TPTA	1 1/2	Oxygen	2.5 X 4 ACME	3.5	
32 CGA-OX-HE-TPTA	2	Oxygen	3 X 4 Stub ACME	3.5	
48 CGA-OX-HE-TPTA	3	Oxygen	4.25 X 4 ACME	3.75	

Fixed End Assembly - Machine Type

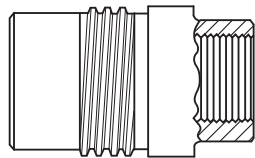

Female End FNPT

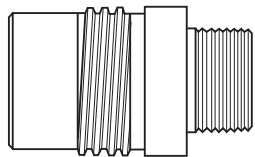

Male End MNPT

Thorburn Part #	Hose Size (in)	Fitting Size (in)	Liquid Service
24 CGA-NI-FE-FNPT-A	1 1/2	1 1/2 FNPT	Nitrogen
24 CGA-NI-FE-MNPT-A	1 1/2	1 1/2 MNPT	Nitrogen
40 CGA-NI-FE-FNPT-A	2 1/2	2 1/2 FNPT	Nitrogen
40 CGA-NI-FE-MNPT-A	2 1/2	2 1/2 MNPT	Nitrogen
24 CGA-AR-FE-FNPT-A	1 1/2	1 1/2 FNPT	Argon
24 CGA-AR-FE-MNPT-A	1 1/2	1 1/2 MNPT	Argon
40 CGA-AR-FE-FNPT-A	2 1/2	2 1/2 FNPT	Argon
40 CGA-AR-FE-MNPT-A	2 1/2	2 1/2 MNPT	Argon
24 CGA-OX-FE-FNPT-A	1 1/2	1 1/2 FNPT	Oxygen
24 CGA-OX-FE-MNPT-A	1 1/2	1 1/2 MNPT	Oxygen
40 CGA-OX-FE-FNPT-A	2	2 FNPT	Oxygen
40 CGA-OX-FE-MNPT-A	3	2 FNPT	Oxygen

Fixed End Flange Assembly For Rail Car & Truck

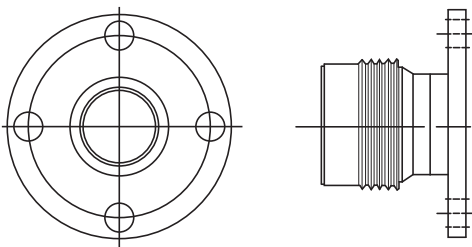

Thorburn Part #	Size (in)	NPT
40 CGA-NI-FE-FLA-S4	2 1/2	Nitrogen
40 CGA-AR-FE-FLA-S4	2 1/2	Argon
32 CGA-OX-FE-FLA-S4	2	Oxygen
48 CGA-OX-FE-FLA-S4	3	Oxygen

Material: Fixed end flanged - Naval brass ASTM B-21 or 304SS

Cryogenic Unloading Hose Assemblies



Thorburn offers the compressed gas industries the broadest range of hose assemblies to better meet each gas' special requirements. Thorburn's CGA96 hose assemblies are especially used to transfer Oxygen O2, Argon Ag, Nitrogen N2, Hydrogen H2 and Helium He. Thorburn's models CGH96 helical lined and CGTR40 teflon lined cryogenic hose assemblies have been specifically designed to reduce the effects of snowballing during CO2 transfer service.

Advantages

- Maximum operating pressure 400 psi
- Operating temperature -452°F. to 1000°F.
- High-pressure hoses available 3500 psi

CRYO-THERM™ Hose Covers

- Design temperature down to -196°C (-321°F) 302°C (575°F)
- Reduces BTU loss per hour by 90% compared to an uninsulated hose assembly with no halogens or ozone depleting chemicals
- Insulation made from Polyamide open cell foam enveloped in a waterproof breathable ballistic nylon laminate
- Polyamide Foams maintain flexibility when saturated in LN2 (-196°C)

Cryo-Therm™ Data

Actual temperature drop between bare hose VS hose with CryoTherm™ covers during transfer of LN2 at -190°C

Minutes of LN2 Flowing	Bare Hose (°C)	Insulated CryoTherm™ Cover (°C)
1	- 48	20
2	-124	18
7	-158	11
9	-173	08
11	-194	04



If the room temperature hose consumes 25 liters with an average fill, the consumption of the same hose with CryoTherm™ will be one tenth of this, 2.5 liters loss per average fill

How To Order Cryogenic Unloading Hose Assemblies

Model	1st End	1st Type	2nd End	2nd Type	Size	Over All Length (in)	Cleaning	Adapter	Armor
CGA96	04	NI	02	NI	32	120*	CO	TPO	AF
CGA96 CGH96 CGTR40	01 = 304SS Female NPT 02 = 316SS Female NPT 03 = 304SS Male NPT 04 = 316SS Male NPT 05 = 304SS Male Hex NPT 06 = 316SS Male Hex NPT	NI =Nitrogen OX =Oxygen AR =Argon CT =Carbon Dioxide Threaded CB =Carbon Dioxide Brazed	16 =1" (25mm) 20 =1 1/4" (32mm) 24 =1 1/2" (38mm) 32 =2" (50mm) 40 =2 1/2" (64mm) 48 =3" (80mm) 64 =4" (100mm)	CO = Clean For Oxygen Service** X = Special Cleaning Specify In House Cleaning System Thorburn has an in-house cleaning system that uses environmentally friendly state of the art technology to remove its emulsifying oils and greases, stains, dirt, grime and other hose contaminants with each and every hose assembly we sell.	Tailplug TPN = Nitrogen TPA = Argon TPO = Oxygen Dust Cap CDC = CO ₂ Dustcap CDP = CO ₂ Tailplug	AF = Full Armor 316SS AE = Armor Sleeve 304SS (Specify Length At Each End in inches or mm) CT = Cryo-Therm Hose Cover			

If "Special Construction" is required... Please add suffix "S" at the end of the part number and specify

* Metric sizes insert "mm" after number
Downsizes insert "D" after End
Upsizes insert "U" after End

Steam Jacketed (Double Containment) Hose Assemblies



Thorburn's TJHS jacketed steam hose assembly with flanged fitting to end joints

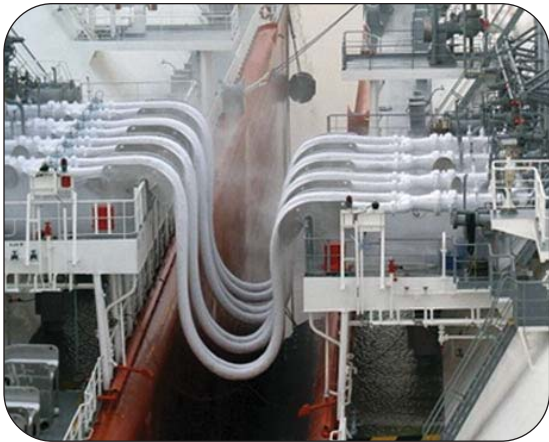

Ship to shore transfer of Liquefied Natural Gas (LNG)

Thorburn's TJH Jacketed Hose Assemblies

are custom designed assemblies (a hose within a hose) consisting of a metallic hose inner core and a larger diameter outer hose. Both inner and outer hoses act independently as separate pressure carriers. Port couplings in the outer hose provide a means to transfer the jacketed media between the hoses. When installing Thorburn's TJH assemblies into a jacketed system, the link between the inner and outer hoses is critical to efficiently transfer the steam, coolant or vacuum between the jacketed components.

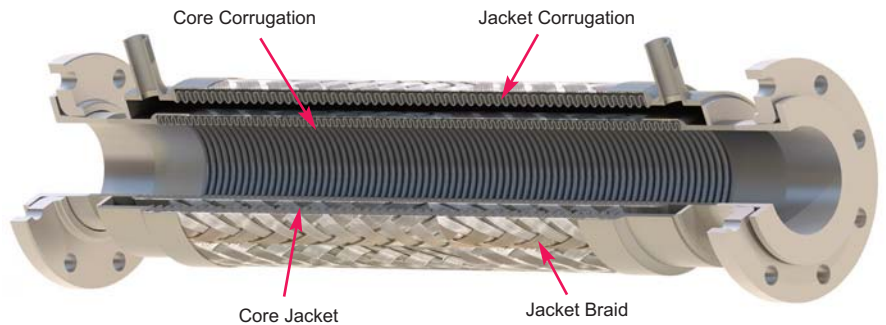

Thorburn's jacketed hose assembly illustration

Applications

Thorburn's TJHS Steam Jacketed Hose Assemblies

are used when the media is viscous and steam is used to help reduce viscosity and increase flow. Applications include transfer of asphalt, pitch, slurry, viscous chemicals, freeze protection and gas & emission sampling.

Thorburn's TJHD Double Containment Jacketed Hose Assemblies

are designed for secondary containment solutions for critical liquids and gases where a failure could compromise safety. If the inner hose containing the hazardous material leaks, it will be caught by the outer jacketed hose without escaping into the environment. Built in warning system can be designed into Thorburn's TJHD hose assembly warning the operator that the inner hose has been breached and a changeout must be done.

Thorburn's TJHC Cryogenic Jacketed Hose Assemblies

Cryogenic hoses are typically insulated by vacuum. The outer assembly is filled with a cold media and acts as an insulator to reduce heat loss when it is desirable to keep the temperature of the inner hose media in a cold state. Applications include the production of liquefied natural gas (LNG) for use as a fuel and feedstocks for various petro-chemicals. Other applications include, transfer of cryogenic liquids such as oxygen, nitrogen and argon, ship to shore transfer, road tanker, rail tanker, food freezing and preservation of medical biological materials.

Temperature when gas changes to liquid at atmospheric pressure

Cryogen	(K)	(°C)	(°F)
Methane	111.7	-151.5	-258.5
Oxygen	90.2	-183.0	-297.3
Nitrogen	77.4	-195.8	-320.4
Hydrogen	20.3	-252.9	-423.2
Helium	4.2	-269.0	-452.1
Absolute Zero	0	-273.2	-459.7

The common gases shown on the table above change from gas to liquid at atmospheric pressure at the temperatures shown, called the Normal Boiling Point (NBP). These liquids are known as cryogenic liquids.

Ordering

To order Thorburn Steam Jacketed Hose Assemblies, please refer to **Page 28**

Sure-Temp Electrically Heated Metallic Hose Assemblies



Applications

Gas Analysis: Sample taking of flue gas from the chimney to the analyzer system.

Automotive: transport of adhesive media in glueing machines for bonding automotive components.

Petrochemical: Freeze protected loading/unloading of viscous materials and corrosive liquids in subzero environments

Filling & Dosing Machines: Precise temperature transport of liquids, oils, fats, pastes, powders, creams, and lotions for packaging in pharmaceutical and food industries.



Thorburn's Sure-Temp hose assembly transporting bitumen

Typical Thorburn Sure-Temp Design

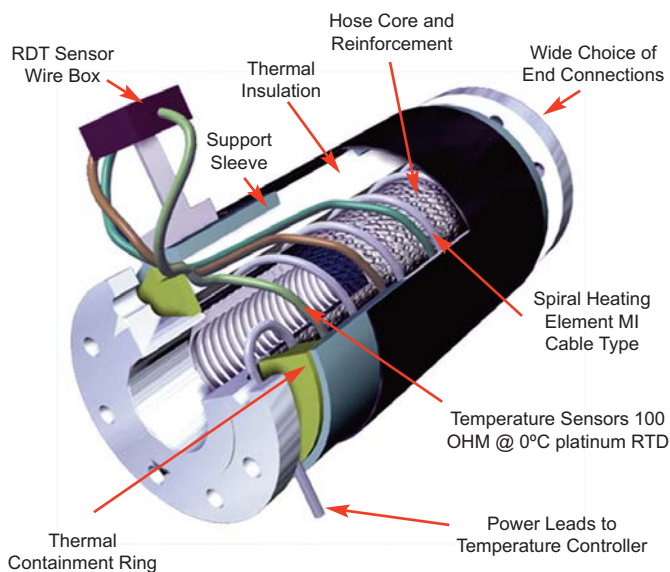

Thorburn Sure Temp technology offers to the industry the widest range of custom built electrically heated hose assemblies. Sure Temp capabilities range from basic freeze protection and gas sampling to transferring viscous materials at precise and uniform temperatures. This enables loading/ unloading of oil, fat, resins, paint, bitumen, adhesives, compounds and foods with maximum efficiency without temperature loss.

Specifications

Heated Pressure Hoses - Gas Analysis:

Frost protection/holding temperatures | 5°C to 450°C

Nominal ID | 4mm to 50mm

Typical Design Pressures | Full vacuum to 300 psi (20 bar)

Heated Pressure Hoses - Liquid Service:

Frost protection/holding temperatures | 5°C to 250°C

Nominal ID | 8mm to 200mm

Typical Design Pressures | Full vacuum to 300 psi (20 bar)

Sure Temp Electrically Heated Hose Assemblies

Available with Factory Mutual Approval for use in Class 1, Div. 2, Group D areas



TFTC-01 Temperature Controllers

The temperature is measured by a sensor processed by the microcontroller and displayed. After comparing actual and preset values, the appropriate output relays are switched

- LED display works to -25°C
- Programmable -50°C to 500°C
- 16A resistive load alarm contact
- Sensors with 2 or 3 wires



Thorburn technicians assembling Sure-Temp electrically heated hose assemblies

ThermaCover™ Removable Thermal Insulation Covers



Temperatures from -100°F (-73°C) to 500°F (260°C)

Process piping and equipment left without a properly designed thermal insulation cover can freeze and fail to properly operate. Thorburn's ThermaCover™ is a removable thermal insulation cover that is used to cover valves, flanges, odd shapes such as expansion joints, and other components, as well as process piping. Unlike permanent hard insulation, Thorburn's ThermaCover™ have the advantage of being removable and reusable, making them the insulation of choice for components that need to be accessed from time to time for maintenance and inspection. Thorburn's ThermaCover™ features sewn construction and can incorporate flap closures and cut-outs to provide easy internal access.

Valves, flanges and expansion joints left uncovered can result in:

- Unnecessary process adjustment due to heat loss.
- False readings or alarms being sent to the control room.
- Equipment failures due to operation outside of normal temperature ranges.
- Degradation of product quality due to improper process temperatures.

ThermaCover™ Benefits

- Heat retention and freeze protection.
- Personnel protection against burns from hot components.
- Energy savings from reduced heat loss to surrounding environment.
- Sound attenuation.
- Insulation Jackets are easily removable for maintenance & inspection.

ThermaCover™ Construction

Material:

Model TCS (Silicone Impregnated Fiberglass)

Temperature Range: -67°F (-55°C) to 500°F (260°C)

Model TCT (PTFE Impregnated Fiberglass)

Temperature Range: -100°F (-73°C) to 500°F (260°C)

Usage: Typical outer cover used in most standard insulation blanket applications. Also used as inner liner for applications < 500°F (260°C) where a fluid barrier or insulation fiber containment is desired.

Special Properties:

- Flexible
- Flame retardant
- Water & oil resistant
- Mould resistant
- Chemical resistant



Thorburn's ThermaCover™ have a bolster bag that encases the insulation materials to permit handling and installation



Thorburn's ThermaCover™ can be used for freeze protection and heat retention

M96ZC Monel Chlorine Transfer Hose Assemblies

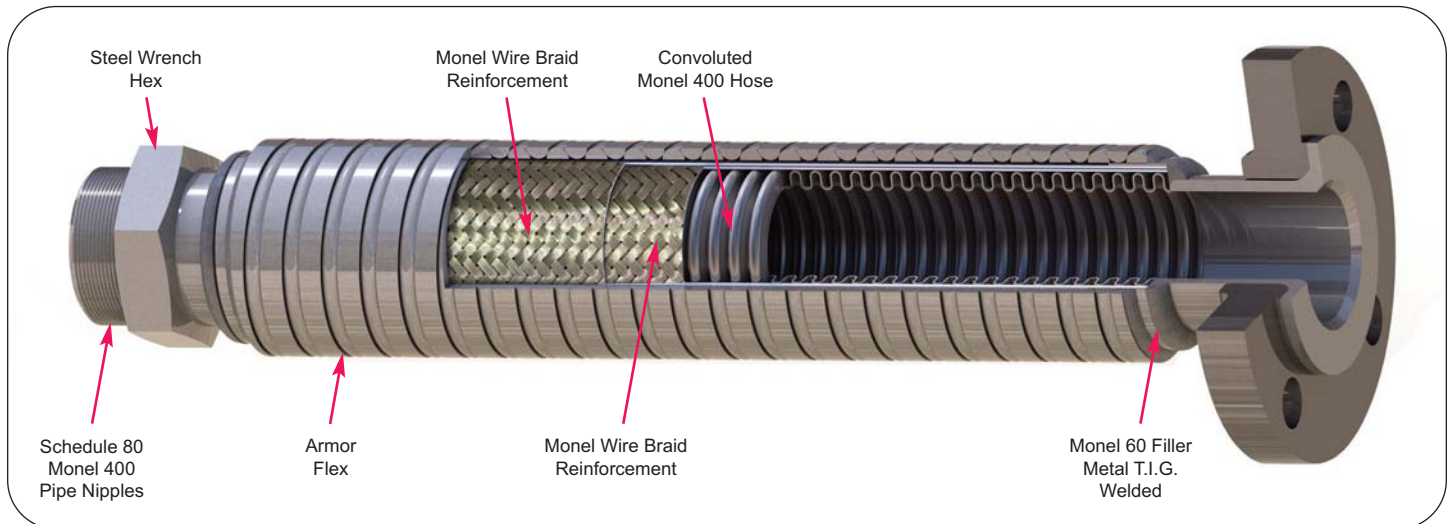

Chlorine gas unloading station

Features

- Indoor Outdoor Service
- Complies with Chlorine Institute Inc. Pamphlet 6, Appendix A
- Quality assurance ISO 9001: 2015
- Welders/welding procedures ASME section IX, VIII B31.1 and B31.3
- All assemblies tested 750 psi
- All assemblies permanently tagged, cleaned and capped



Chlorine gas feed system

How to Order Thorburn M96ZC Hose Assemblies

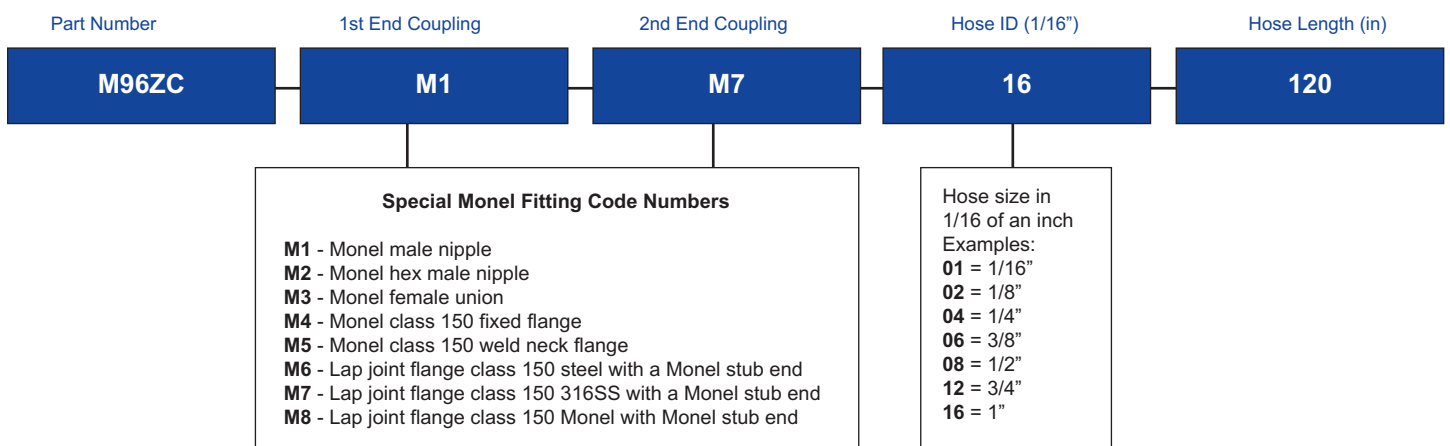

CGA96/UL96 Metal Hose Assemblies

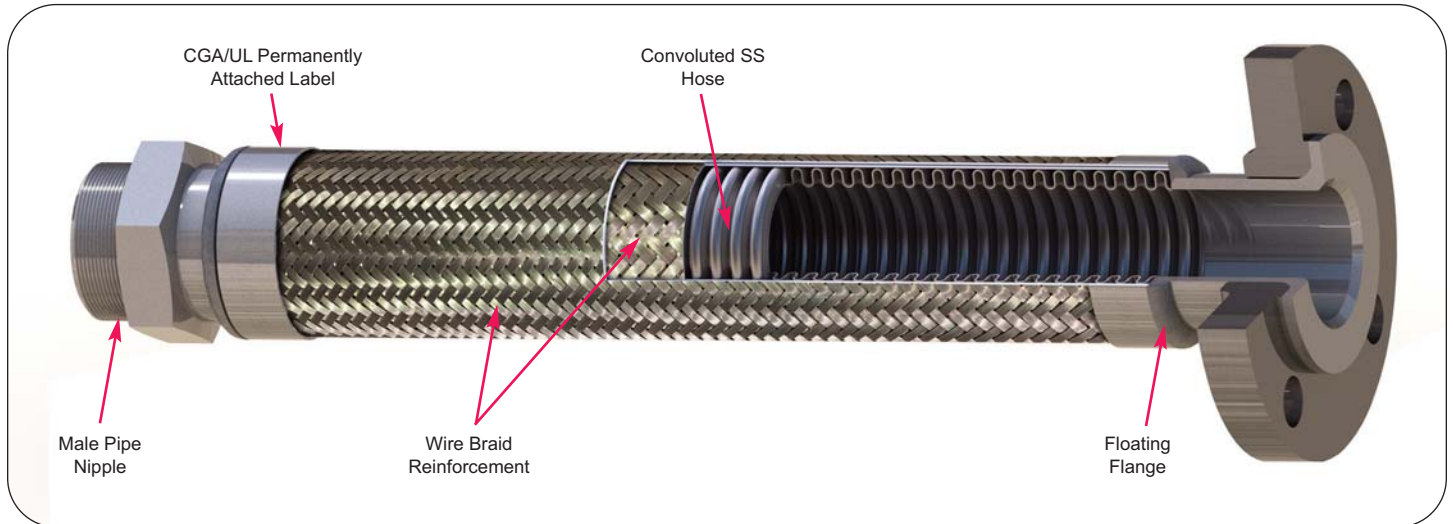

Thorburn CGA96/UL96 stainless steel flexible hose assemblies are designed to meet all the requirements of both the Canadian Gas Association and the American Gas Association for transferring natural gas, propane, anhydrous ammonia, methane and sour gas. Thorburn hose assemblies are designed to meet the Canadian Certification requirements CR96-001 and the American Certification requirements UL536.

Applications

- Natural gas
- Propane
- Anhydrous ammonia
- Methane
- Sour gas

Specifications			
Size Range		Pressure Rating	
(in)	(mm)	(psi)	(bar)
1/4 - 2	6 - 50	350	24.13
2 1/2 - 3	65 - 80	250	17.24
4 - 6	100 - 150	200	13.79

How to Order Thorburn CGA96/UL96 Hose Assemblies



CGA96
UL96

Special Monel Fitting Code Numbers	
01 Male nipple carbon steel	20 Weld neck flange carbon steel 300 lbs
02 Male nipple 304 SS	21 Weld neck flange 304 SS 300 lbs
03 Male nipple 316 SS	22 Weld neck flange 316 SS 300 lbs
04 Hex male carbon steel	23 Lap joint flange carbon steel 300 lbs
05 Hex male 304 SS	24 Lap joint flange and stub end 304 SS 300 lbs
06 Hex male 316 SS	25 Lap joint flange and stub end 316 SS 300 lbs
14 Weld nipple carbon steel 300lbs	26 Lap joint flange carbon steel stub end 304 SS 300 lbs
16 Weld nipple 316 SS	27 Lap joint flange carbon steel stub end 316 SS 300 lbs
17 Fixed flange carbon steel 300 lbs	36 Carbon steel female 37° swivel
18 Fixed flange 304 SS 300 lbs	37 316 SS female 37° swivel
19 Fixed flange 316 SS 300 lbs	

Thor-Loop™ Flexible Pipe Loops

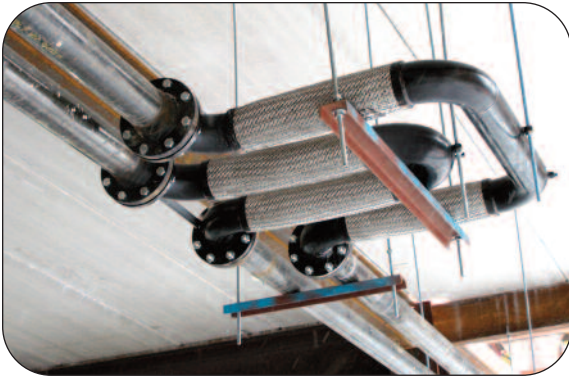

Thorburn's Thor-Loop™ Series UL Flexible Pipe Loops

Thor-Loop™ is a custom flexible pipe loop engineered to absorb up to 500 mm (20 in) of movement in all directions, providing superior protection in demanding piping systems.

Features

- Absorbs thermal (axial) and seismic movement in all directions - U-type (TL) & V-type (VL)
- UL-listed and CGA-certified, ideal for fire sprinkler and gas-fired equipment systems.
- Protects boilers, chillers, and connected equipment during seismic events.
- Prevents nozzle cracking, shearing, and pipe stress, ensuring long service life.
- Low anchor loads compared to bellows and hard pipe loops for easier installation.
- Versatile configurations, including double-containment, steam-jacketed, or buried loops

Applications

- Nozzle load relief for equipment and tanks
- Fire sprinkler and gas system connections
- Buried or space-restricted piping systems

Thor-Loop™ vs Metallic Bellows vs Hard Pipe Loop Comparison

G = Guide IA = Intermediate Anchor MA = Main Anchor

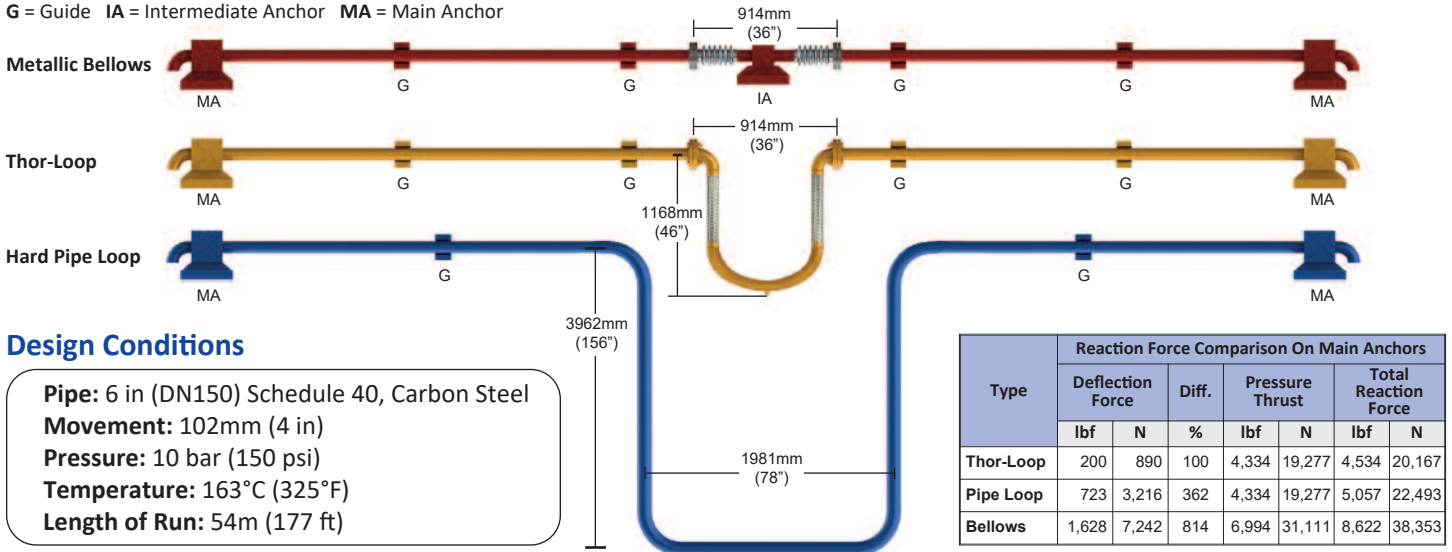

Design Conditions

Pipe: 6 in (DN150) Schedule 40, Carbon Steel
Movement: 102mm (4 in)
Pressure: 10 bar (150 psi)
Temperature: 163°C (325°F)
Length of Run: 54m (177 ft)

How to Order Thorburn Thor-Loop™ Hose Assemblies

Note: Thor-Loop™ hose assemblies installed in any orientation other than hanging down must have the 180° return supported. If the 180° return bend is made of different material than the end fittings, please specify.

Thor-Loop	Type	Hose	Size	Pressure	1st End	1st End Material	2nd End	2nd End Material	Dimension A	Dimension B	Accessories
(N)TL	02	S96	32	300	01	S6	40	S6	14	24.5	SB
(N)TL - U-Loop (N)VL - V-Loop		S96 S96Z S92 S92Z B96 B96Z	08 = 1/2" (DIN15) 12 = 3/4" (DIN20) 16 = 1" (DIN25) 20 = 1 1/4" (DIN32) 24 = 1 1/2" (DIN40) 32 = 2" (DIN50) 40 = 2 1/2" (DIN65) 48 = 3" (DIN80) 64 = 4" (DIN100)		01 - Elbow Male NPT Nipple 14 - Elbow Weld End 17A(150) - Elbow Flange 150# 17A(300) - Elbow Flange 300# 17(PN10) - Elbow Flange PN10 17(PN25) - Elbow Flange PN25 25 - Lapjoint Flange SS316 150# Stub SS316 26 - Lapjoint Flange CS 150# Stub SS316 40 - Elbow Victaulic 43 - Elbow Female Copper Sweat End				See Movement Charts on page 57		DP = Drain Plug SB = Support Bracket XX = Specify return bend material if different than end material
	01 - Hanging Down 02 - Hanging Up 03 - Hanging Sideways							CS = Carbon Steel S4 = 304SS S6 = 316SS B = Brass			

Notes: Prefix (N) is used for code compliance. When Nuclear Class 2, 3 or 4 is required insert NC2 for Class 2, NC3 for Class 3 & NC4 for Class 4 at the end of the part number. Class 6 use prefix (N) only.

Note: For additional End Connection types, Please see Page 25

Thor-Loop™ Flexible Pipe Loops

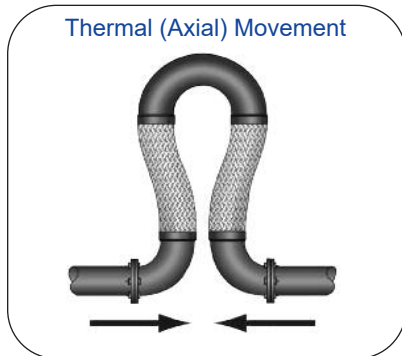

Thor-Loop's flexible elements are designed with sufficient live length with the offset amount never exceeding the elastic limit and therefore will flex indefinitely

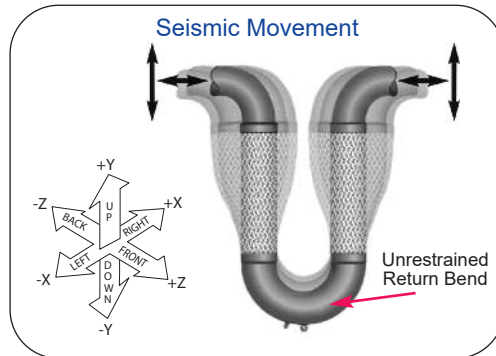

The randomness of movement in an earthquake requires Thor-Loop™ be capable of movement in all directions

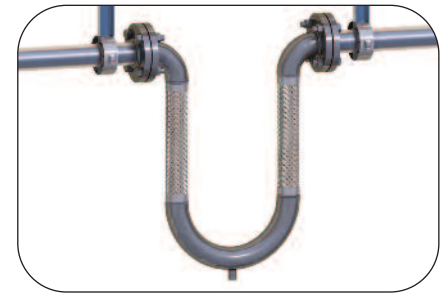

Hanging Down (Code 01)

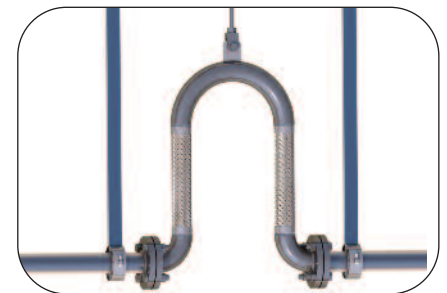

Hanging Up (Code 02)



Hanging Sideways (Code 03)



Thor-Loop Series VL "V-Loop"

Thor-Loop Series VL "V-Loop" is a compact design that provides greater movement than Thorburn Series TL "U-Loop" in more compact spaces.

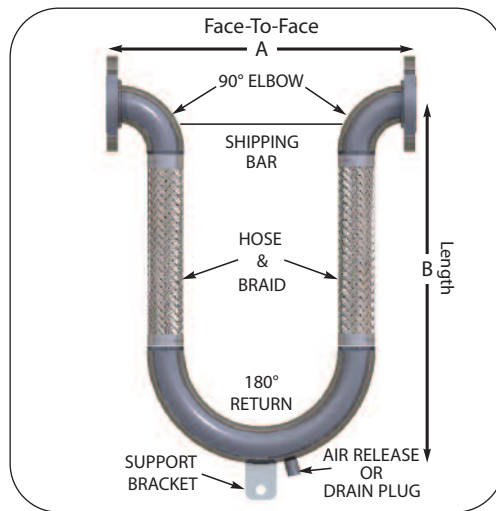

Thor-Loop™ Movement Selection Charts

Threaded/Welded Ends With Typical OAL Dimensions

Pipe Size inch (DIN)	Movement inch (mm)	Threaded Face-Face (A) inch (mm)	Welded Face-Face (A) inch (mm)	Length (B) inch (mm)
1/2 (12.7)	±1.5 (38)	12 (300)	6 (153)	11 (280)
	±4 (100)	15 (381)	9 (229)	16 (407)
3/4 (20)	±1.5 (38)	13 (330)	6 (153)	11 (280)
	±4 (100)	16 (407)	10 (254)	18 (457)
1 (25)	±1.5 (38)	12 (300)	6 (153)	12 (300)
	±4 (100)	16 (407)	10 (254)	19 (483)
1 1/4 (32)	±1.5 (38)	13 (330)	8 (204)	14 (356)
	±4 (100)	17 (432)	11 (280)	20 (508)
1 1/2 (38)	±1.5 (38)	15 (381)	9 (229)	15 (381)
	±4 (100)	18 (457)	12 (305)	22 (559)
2 (50)	±1.5 (38)	18 (457)	12 (305)	18 (457)
	±4 (100)	20 (508)	14 (356)	25 (635)
2 1/2 (63.5)	±1.5 (38)	21 (534)	15 (381)	21 (534)
	±4 (100)	22 (559)	16 (407)	29 (737)
3 (80)	±1.5 (38)	26 (661)	18 (457)	24 (610)
	±4 (100)	28 (712)	20 (508)	30 (762)
4 (100)	±1.5 (38)	32 (813)	24 (610)	28 (712)
	±4 (100)	34 (864)	26 (661)	36 (915)

Flanged Ends With Typical OAL Dimensions

Pipe Size inch (DIN)	Movement inch (mm)	Face-Face (A) inch (mm)	Length (B) inch (mm)
2 (50)	±1.5 (38)	13 (330)	18 (457)
	±4 (100)	15 (381)	25 (635)
2 1/2 (63.5)	±1.5 (38)	16 (407)	21 (534)
	±4 (100)	18 (457)	29 (737)
3 (80)	±1.5 (38)	19 (483)	24 (610)
	±4 (100)	21 (534)	30 (762)
4 (100)	±1.5 (38)	25 (635)	28 (712)
	±4 (100)	27 (686)	36 (915)
5 (127)	±1.5 (38)	31 (788)	33 (839)
	±4 (100)	33 (839)	41 (1042)
6 (153)	±1.5 (38)	37 (940)	37 (940)
	±4 (100)	39 (991)	46 (1169)
8 (204)	±1.5 (38)	49 (1245)	45 (1143)
	±4 (100)	51 (1296)	54 (1372)
10 (254)	±1.5 (38)	61 (1550)	54 (1372)
	±4 (100)	63 (1601)	64 (1626)
12 (305)	±1.5 (38)	73 (1855)	62 (1575)
	±4 (100)	75 (1906)	73 (1855)

Note: The dimensions above should be viewed as estimates. Exact dimension are determined by application.

Metal Hose Technical Data

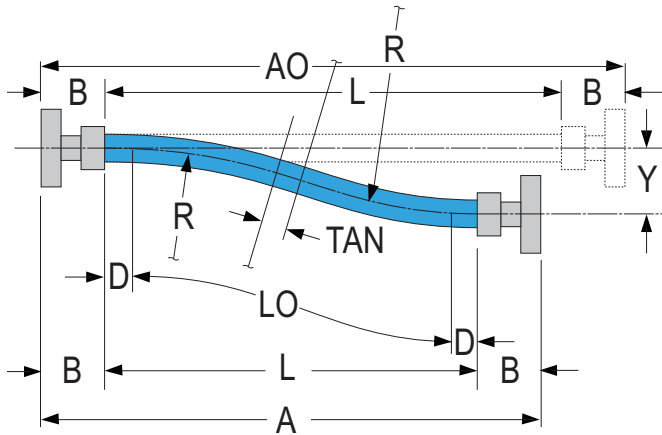

$$A = L + 2*B$$

$$L = LO + 2*D$$

$$LO = 2*Rs*acos((Rs-Y)/2*Rs)$$

See table below for sample calculated value of LO

Offset Installation

Metallic hose is installed S-shaped to accommodate offset (Y) between two mating flanges or connecting ends of the piping. To be used for static offset installation not for dynamic movement due to piping thermal expansion or vibration. Maximum offset (Y) to be 50% of hose minimum static bend radius (Rs): $Y=0.5*Rs$

- AO** = Face to Face dimension for straight (as built) hose assembly
- A** = Face to Face for installation
- B** = Length of end connector
- D** = Outside diameter of the hose
- L** = Total live length of the hose
- LO** = Minimum live length for offset installation
- R** = Bend radius of the offset installation ($R \geq Rs$)
- Rs** = Minimum static bend radius for hose
- Y** = Lateral offset of the installation

Min. Bend Radius (in)	Y= Offset Installation (in)															
	1/8	1/4	3/8	1/2	3/4	1	1 1/2	2	3	4	5	6	8	10	20	30
	LO= Calculated Minimum Length for Offset Bending (in)															
2	1.00	1.42	1.75	2.02	2.49	2.89	3.58									
4	1.42	2.01	2.46	2.84	3.49	4.04	4.98	5.78								
6	1.73	2.45	3.01	3.48	4.27	4.93	6.06	7.03	8.67							
8	2.00	2.83	3.47	4.01	4.92	5.69	6.98	8.09	9.96	11.56						
10	2.24	3.17	3.88	4.48	5.49	6.35	7.80	9.02	11.10	12.87	14.45					
12	2.45	3.47	4.25	4.91	6.02	6.95	8.53	9.87	12.13	14.06	15.77	17.35				
14	2.65	3.74	4.59	5.30	6.50	7.51	9.21	10.65	13.08	15.15	16.99	18.67				
16	2.83	4.00	4.90	5.66	6.94	8.02	9.84	11.37	13.97	16.17	18.13	19.92	23.13			
18	3.00	4.25	5.20	6.01	7.36	8.51	10.43	12.06	14.80	17.13	19.20	21.08	24.47			
20	3.16	4.47	5.48	6.33	7.76	8.96	10.99	12.70	15.59	18.04	20.21	22.19	25.74	28.91		
25	3.54	5.00	6.13	7.08	8.07	10.02	12.28	14.19	17.41	21.14	22.55	24.75	28.68	32.18		
30	3.87	5.48	6.71	7.75	9.50	10.97	13.44	15.54	19.05	22.03	24.67	27.06	31.34	35.14		
35	4.18	5.92	7.25	8.37	10.26	11.85	14.52	16.77	20.57	23.78	26.62	29.19	33.79	37.88	54.26	
40	4.47	6.33	7.75	8.95	10.96	12.66	15.52	17.93	21.98	25.40	28.43	31.18	36.08	40.43	57.82	
45	4.74	6.71	8.22	9.49	11.63	13.43	16.45	19.01	23.30	26.93	30.14	33.05	38.23	42.83	61.17	
50	5.00	7.07	8.66	10.00	12.26	14.15	17.34	20.03	24.56	28.38	31.76	34.82	40.27	45.10	64.35	79.54
60	5.48	7.75	9.49	10.96	13.42	15.50	18.99	21.94	26.89	31.07	34.76	38.11	44.06	49.34	70.28	86.73
70	5.92	8.37	10.25	11.84	14.50	16.74	20.51	23.69	29.03	33.55	37.53	41.14	47.56	53.24	75.75	93.37
80	6.32	8.95	10.96	12.65	15.50	17.90	21.93	25.32	31.03	35.85	40.10	43.96	50.81	56.87	80.86	99.58
90	6.71	9.49	11.62	13.42	16.44	18.98	23.25	26.86	32.91	38.02	42.53	46.61	53.87	60.28	85.66	105.42
100	7.07	10.00	12.25	14.15	17.33	20.01	24.51	28.31	34.68	40.07	44.82	49.11	56.76	63.51	90.21	110.96
110	7.42	10.49	12.85	14.84	18.17	20.98	25.71	29.69	36.37	42.02	46.99	51.50	59.51	66.59	94.53	115.24
120	7.75	10.96	13.42	15.49	18.98	21.92	26.85	31.01	37.99	43.88	49.08	53.78	62.14	69.52	98.67	121.29

Note: Applicable for static bend only

Computing Minimum Lengths for 45°, 90°, and 180° Bends of Thorburn Metal Hose Assemblies

Determine the centerline bend radius required for your application. Under the column headed "Centerline bend radius in inches", find your radius and read horizontally to the desired degree of bend (45°, 90° or 180°).

The number in that column will be the minimum live length required to make that degree of bend along the desired centerline radius.

Note: Add fitting length dimension "A" plus the minimum live length to calculate OAL.

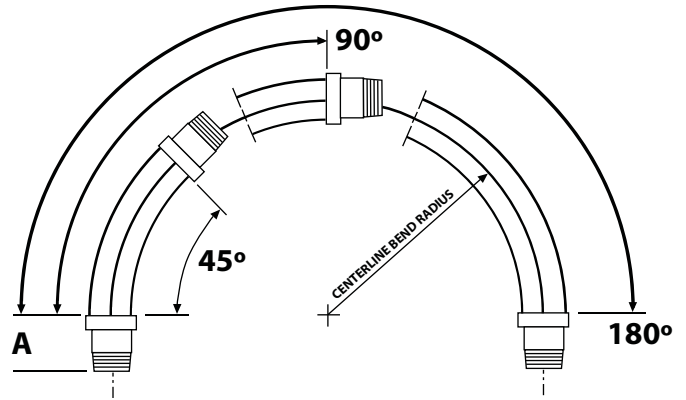

Centerline Bend Radius (in)	Minimum Live Length (in)		
	45°	90°	180°
1	1	2	4
2	2	3 1/2	7
3	2 1/2	5	10
4	3 1/2	6 1/2	13
5	4	8	16
6	5	10	20
7	5 1/2	11	22
8	6 1/2	13	26
9	7 1/2	14 1/2	29
10	8	16	32
11	9	18	36
12	10	19 1/2	39
13	10 1/2	21	42
14	11 1/2	22 1/2	45
15	12	24	48
16	13	26	52
17	13 1/2	27	54
18	14 1/2	29	58
19	15 1/2	30 1/2	61
20	16	32	64
21	17	33 1/2	67
22	17 1/2	35	70
23	18 1/2	36 1/2	73
24	19	38	76
25	20	40	80

Centerline Bend Radius (in)	Minimum Live Length (in)		
	45°	90°	180°
26	21	42	83
27	21 1/2	43	86
28	22 1/2	44 1/2	89
29	23	46	92
30	24	48	95
31	24 1/2	49	98
32	25 1/2	51	101
34	27	54	108
36	28 1/2	57	114
38	30	60	120
40	32	63	126
45	36	72	144
50	40	80	160
55	45	90	180
60	49	97	194
65	53	105	210
70	56	112	224
80	65	130	260
90	73	145	290
100	80	160	320
120	95	190	380
140	112	225	450
160	128	255	510
180	148	285	570
200	160	320	640

Installing Thorburn Hose Assemblies

Thorburn flexible metal hose assemblies are manufactured to the highest quality levels to assure maximum service life. The following precautions should be adhered to when installing a flexible metal hose assembly.

Avoid Improper Handling

Thorburn metal hose can be damaged by dragging or when subjected to external abrasive or corrosive conditions. Avoid installing hose in areas where it may be subjected to corrosive sprays, spills, etc.

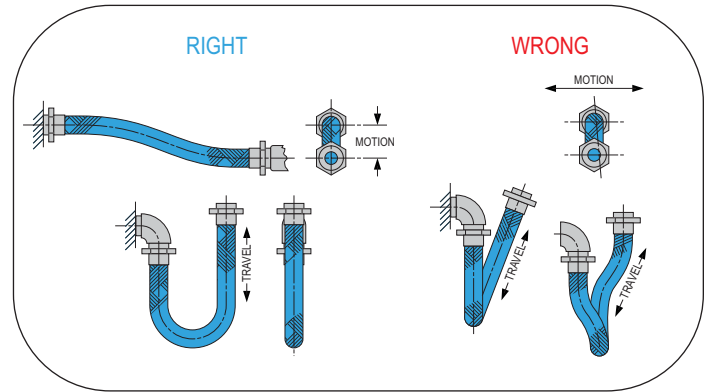
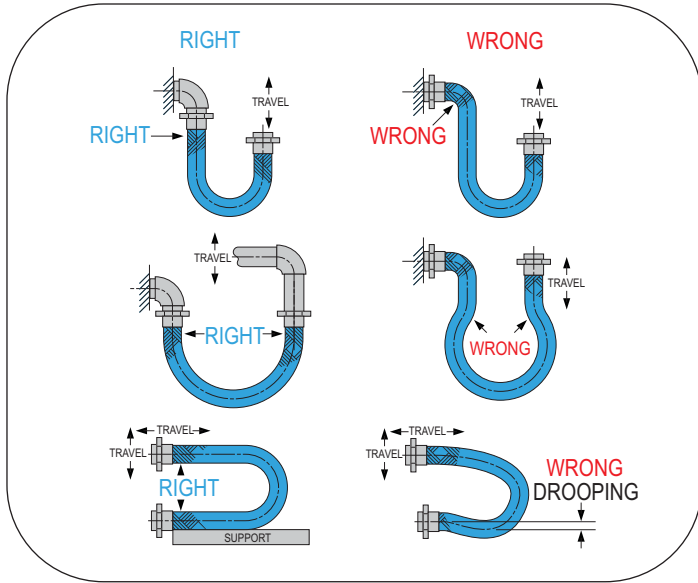

Avoid Torque

Torquing or twisting Thorburn metal hose reduces service life substantially. When installing metal hose, it is important that all movement originates in the same plane as the center line. Another precaution against torque is the use of a floating flange or union on one end of the assembly.

Avoid Overbending

Overbending Thorburn metal hose can result in premature failure. This often occurs at the end connections and may be avoided by installing an elbow or interlock guard.

Calculations for minimum live length excluding end fittings

Thorburn flexible metallic hose assemblies are usually flexed in accordance with one or a combination of the modes of motion shown below. To obtain maximum reliability it is essential to calculate the length of an assembly that will not be flexed beyond the minimum bend radius. The following formulas give a guide in determining the length of tube required. They are based on standard applications using our current product range. Variations should be discussed with our technical dept.

- L** = Minimum Live Length excluding end fitting
- R** = Minimum Bend Radius
- T** = Total Travel
- K** = Loop Length
- π = 3.142

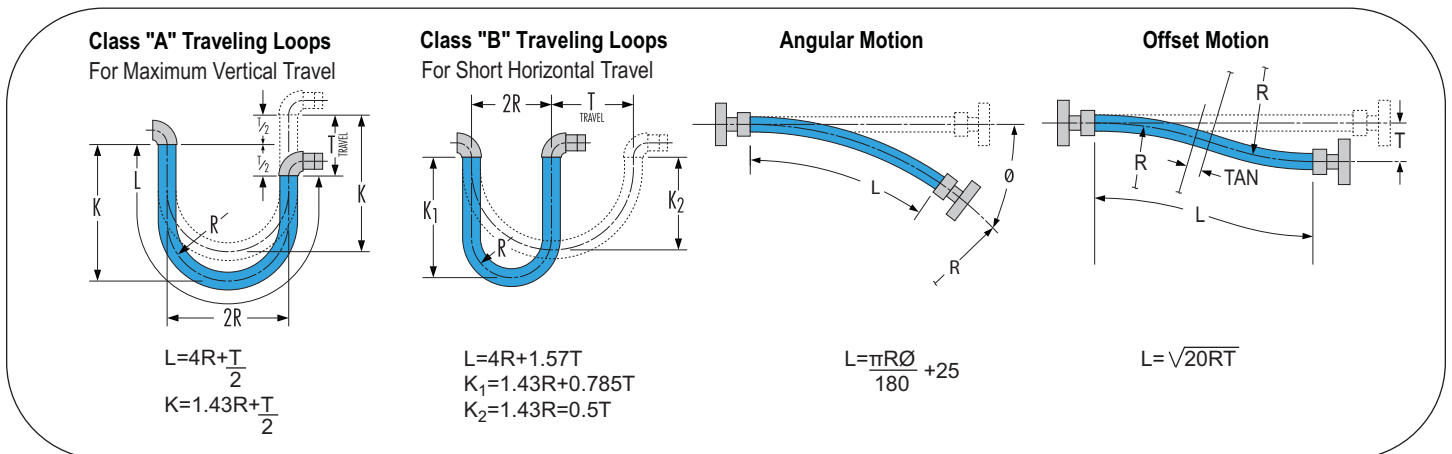

Pipe Anchoring Guide

A piping system which utilizes Thorburn flexible metal hose assemblies to absorb pipe movement must be properly anchored and guided to assure correct functioning and maximum service life of the metal hose. The basic principles to be observed are:

- 1) The direction of pipe motion must be perpendicular to the center line (axis) of the hose.
- 2) The pipe must be anchored at each change of direction where a flexible metal hose is employed to prevent torsional stress.

Typical examples of correct and incorrect guiding are shown below.

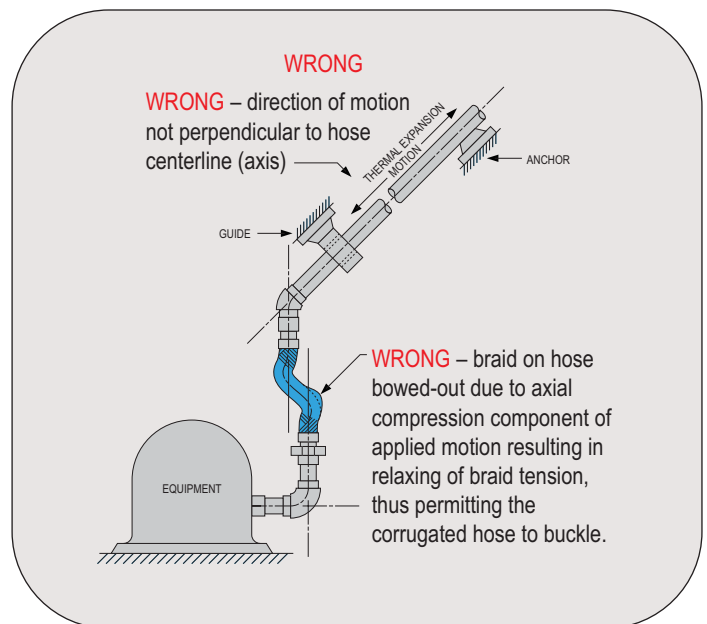
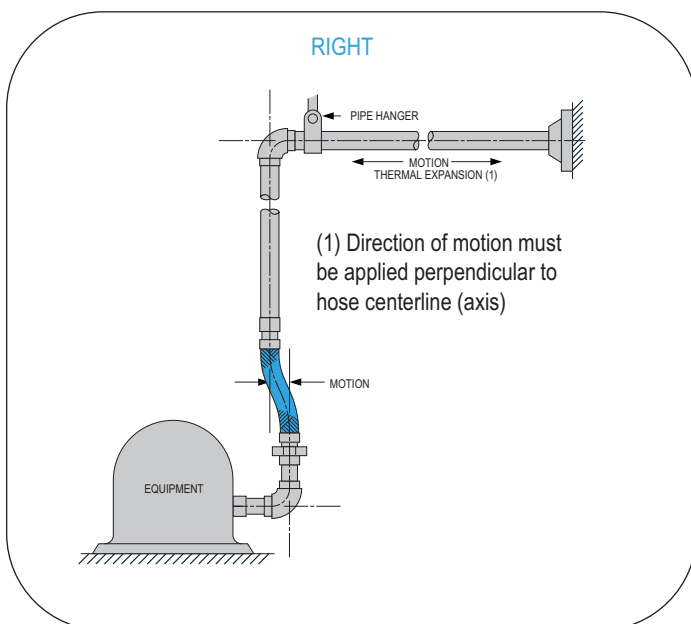
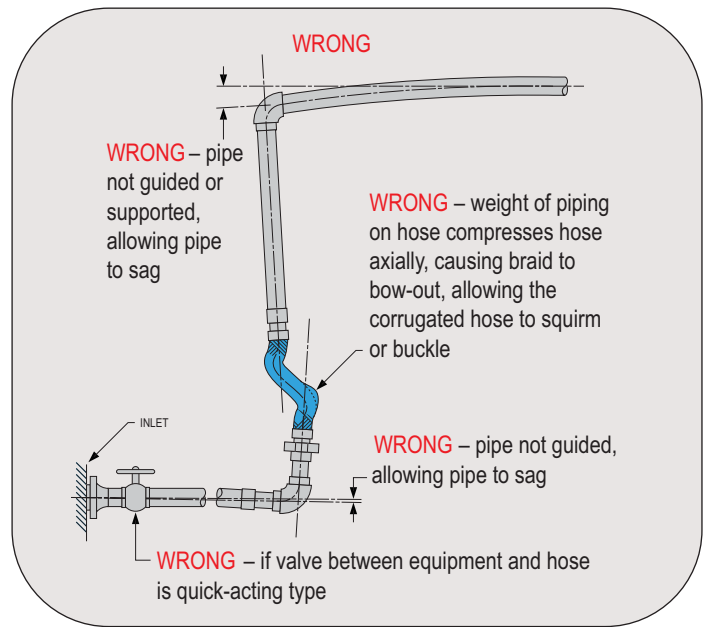
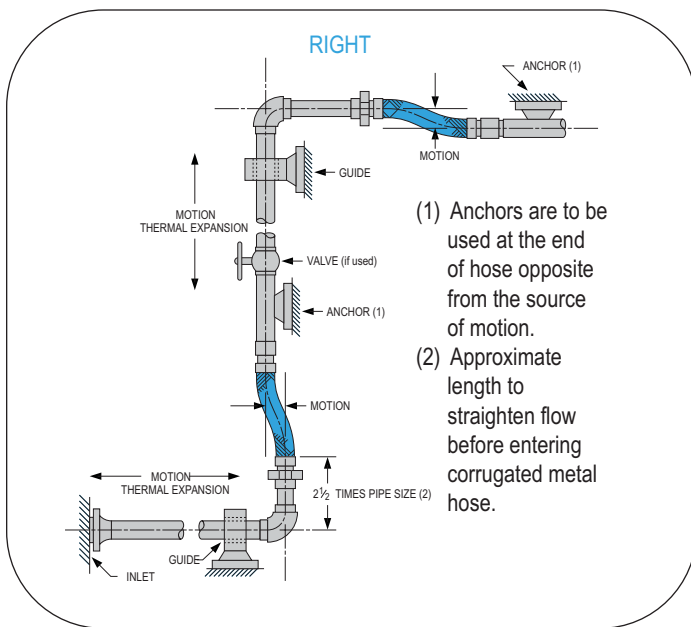

Selection Factors

Maximum Service Temperature			
Alloy	Max. Temp °F	Alloy	Max. Temp °F
ANSI Stainless Steel		Brazing (RCuZn-C or BCuP-2)	
321	1500	Bronze Hose	450
316 ELC	1500	Steel Hose	850
304L	1500	Silver Brazing (AWS-BAg-2)	600
304, 316	850		
302	850	Asbestos Packing Grade: Commercial	
Mild Steel	850	Underwriters	450
Malleable Iron	800	Aluminum 52S-0 (5052-0)	450
Monel	800	Galvanizing	600
Bronze	450		450
Brass	450	Soft Solder (Pb: 60, Sn: 40)	250
Copper	400	(Pb: 95, Sn: 5)	350

Shock Pressure

When pulsating, surge or shock pressures exist, these have a marked effect on the service life of metal hoses. If this situation is encountered, the peak pressure must not exceed 50% of the maximum working pressure.

Flow Velocity

High velocities in corrugated hose should be avoided as the corrugations could be forced into resonant vibrations resulting in premature fatigue failure. Where the flow velocity exceeds 100 ft/sec for gas or 50 ft/sec for liquid in unbraided hose and 150 ft/sec for gas or 75 ft/sec for liquid in braided hose, an interlock hose should be used as a liner. When the hose is installed in a bent condition, these flow values should be reduced by 50% for a 90° bend, 25% for a 45° bend and so on, proportionally to the angle of bend. Where velocity exceeds the above values, the next larger size of hose with liner should be used.

Pressure Loss

As a rough estimate, it can be assumed that the pressure loss in corrugated hoses is 100% higher than in new welded steel pipes, and in stripwound hoses it is 20% higher. This means that in the case of corrugated hoses an increase in diameter of 15% and in the case of stripwound hoses of only 4% is sufficient to reduce the pressure loss to the value of the pressure loss in steel pipes.

Temperature Correction Factors For reducing Pressure											
Temperature		Material									
(°F)	(°C)	304	304L	316	316L	321	C276	Monel 400	Inconel 600	Inconel 625	CS
100	38	1.00	1.00	1.00	1.00	1.00	1.00	1.00	1.00	1.00	1.00
200	93	1.00	1.00	1.00	1.00	1.00	1.00	0.88	1.00	1.00	1.00
300	149	1.00	1.00	1.00	1.00	1.00	1.00	0.82	1.00	1.00	1.00
400	204	0.94	0.93	0.97	0.93	1.00	1.00	0.79	1.00	1.00	1.00
500	260	0.88	0.86	0.90	0.86	0.96	0.99	0.79	1.00	0.97	0.95
600	316	0.82	0.81	0.85	0.81	0.91	0.93	0.79	1.00	0.95	0.87
650	343	0.71	0.79	0.84	0.79	0.89	0.90	0.79	1.00	0.94	0.85
700	371	0.80	0.77	0.82	0.77	0.87	0.88	0.79	1.00	0.93	0.83
750	399	0.78	0.75	0.81	0.75	0.86	0.86	0.79	1.00	0.93	0.65
800	427	0.76	0.74	0.80	0.74	0.84	0.84	0.79	1.00	0.93	0.54
850	454	0.75	0.72	0.79	0.72	0.83	0.83	0.79	0.99	0.93	0.44
900	482	0.73	0.71	0.78	0.71	0.82	0.82	0.76	0.95	0.93	0.33
950	510	0.72	0.69	0.77	0.69	0.81	0.81	0.71	0.95	0.93	0.23
1000	538	0.69	0.67	0.77	0.67	0.80	0.80	0.48	0.42	0.93	
1050	566	0.61	0.65	0.73	0.65	0.68	0.68		0.27	0.93	
1100	593	0.49	0.61	0.62	0.61	0.55	0.55		0.20	0.69	
1150	621	0.39	0.53	0.49	0.52	0.47	0.47			0.57	
1200	649	0.30	0.28	0.37	0.38	0.36	0.36			0.36	
1250	677	0.24	0.28	0.28	0.28	0.29	0.29				
1300	704		0.21	0.21	0.21						

Coefficients for Increasing Bend Radius At Elevated Temperatures		
Temperature	Bend Radius	
70°F	21°C	1.00
210°F	100°C	1.10
300°F	150°C	1.25
400°F	204°C	1.30
570°F	300°C	1.40
750°F	400°C	1.50
930°F	500°C	1.60
1110°F	600°C	1.80

Saturated Steam Pressure - Temperature							
Saturated Steam Pressure (psig)	Temperature (°F)	Saturated Steam Pressure (psig)	Temperature (°F)	Saturated Steam Pressure (psig)	Temperature (°F)	Saturated Steam Pressure (psig)	Temperature (°F)
--	0	0	212	150	366	450	460
29.84	20	10	238	175	377	475	465
29.74	32	20	259	200	388	500	470
29.67	40	30	274	225	397	550	480
29.39	60	40	287	250	406	600	489
28.89	80	50	298	275	414	700	505
27.99	100	60	307	300	422	800	520
26.48	120	75	320	325	429	900	534
24.04	140	80	324	350	436	1000	546
20.27	160	90	331	375	442	1250	574
14.63	180	100	338	400	448	1500	606
6.46	200	125	353	425	454	2500	669

Thermal Expansion of Pipe

Examples:

A 3" steel pipe line is 138 feet long. Maximum temperature the line will encounter is 400°F. Lowest temperature is 20°F.

Calculation:

From the chart, the expansion of steel pipe at:

440 °F 3.595 inches per
100 feet of
pipe

20 °F 0.148 inches per
100 feet of
pipe

Difference:

3.447 inches per
100 feet of
pipe

$$\frac{138 \times 3.447}{100} = 4.75" \text{ Appr.}$$

4-3/4" total traverse

A 4" stainless steel line is 50 feet long. Maximum temperature the line will encounter is approximately 580°F. Lowest temperature is approximately -180°F.

Calculation from the chart:

The expansion of stainless steel pipe at:

580°F 6.835 inches per
100 feet of
pipe

the contraction of stainless steel pipe at:

-180°F -1.850 inches per
100 feet of
pipe

Total Movement:

8.685 inches per 100 feet of pipe:

$$\frac{50 \times 8.685}{100} = 4.342 \text{ Appr.}$$

4-11/32" total traverse

From the "Piping Handbook" by Sabin Crocker, McGraw-Hill Publishing Co.

* Monel is a registered trademark of International Nickel Co.

Note: This data is for information and does not suggest that the materials are suitable for all temperatures shown and should only be used as a guide.

Saturate steam vacuum in. Hg below 212 °F, Pressure psi gauge above 212 °F	THERMAL EXPANSION OF PIPE (in inches per 100 feet)										
	Temperature (°F)	Cast Iron	Carbon & Molybdenum Steel	Wrought Iron	4-6% Cr Alloy Steel	12% Cr Alloy Steel	18% Cr - 8 Ni Stainless Steel	Copper	Brass	Aluminum 6061 Alloy	Monel Alloy 400
Vacuum Inches of Hg	-320					-1.770	-3.110	-2.975		-3.96	-2.60
	-300					-1.670	-2.930	-2.805		-3.71	-2.44
	-260					-1.570	-2.750	-2.635		-3.46	-2.28
	-260					-1.470	-2.570	-2.465		-3.21	-2.12
	-240					-1.370	-2.390	-2.295		-2.96	-1.96
	-220					-1.270	-2.210	-2.125		-2.71	-1.80
	-200	-1.058	-1.282	-1.289	-1.250	-1.170	-2.030	-1.955	-2.065	-2.46	-1.64
	-180	-0.982	-1.176	-1.183	-1.150	-1.070	-1.850	-1.782	-1.890	-2.22	-1.48
	-160	-0.891	-1.066	-1.073	-1.030	-0.970	-1.670	-1.612	-1.705	-1.97	-1.32
	-140	-0.797	-0.948	-0.955	-0.970	-0.870	-1.480	-1.428	-1.508	-1.73	-1.15
	-120	-0.697	-0.826	-0.833	-0.800	-0.750	-1.300	-1.235	-1.308	-1.47	-0.98
	-100	-0.593	-0.698	-0.705	-0.700	-0.630	-1.100	-1.040	-1.098	-1.22	-0.82
-80	-0.481	-0.563	-0.570	-0.550	-0.520	-0.880	-0.835	-0.888	-0.98	-0.66	
-60	-0.368	-0.428	-0.435	-0.430	-0.400	-0.670	-0.630	-0.673	-0.74	-0.49	
-40	-0.248	-0.288	-0.295	-0.290	-0.270	-0.450	-0.421	-0.452	-0.49	-0.32	
-20	-0.127	-0.145	-0.152	-0.145	-0.130	-0.225	-0.210	-0.227	-0.25	-0.17	
0	0	0	0	0	0	0	0	0	0	0	
20	0.128	0.148	0.154	0.140	0.140	0.223	0.238	0.233	0.34	0.197	
Vacuum Inches of Hg	32	0.209	0.230	0.249	0.234	0.234	0.356	0.366	0.373	0.54	0.315
	40	0.263	0.285	0.313	0.280	0.280	0.446	0.451	0.466	0.68	0.394
	60	0.391	0.448	0.468	0.430	0.430	0.669	0.684	0.690	1.01	0.591
	80	0.522	0.580	0.628	0.600	0.600	0.892	0.896	0.920	1.35	0.790
	100	0.660	0.753	0.787	0.750	0.750	1.115	1.134	1.150	1.69	0.985
	120	0.799	0.910	0.958	0.900	0.900	1.338	1.366	1.390	2.02	1.18
	150	0.924	1.064	1.113	1.050	1.050	1.545	1.590	1.625	2.36	1.38
	160	1.073	1.223	1.275	1.220	1.220	1.784	1.804	1.865	2.68	1.58
	180	1.218	1.383	1.445	1.370	1.370	2.000	2.051	2.100	3.03	1.77
	200	1.368	1.546	1.626	1.520	1.520	2.230	2.296	2.340	3.38	1.97
	212	1.451	1.643	1.721	1.600	1.600	2.361	2.428	2.467	3.59	2.09
	220	1.507	1.707	1.784	1.675	1.675	2.460	2.516	2.580	3.72	2.17
Vacuum Inches of Hg	240	1.653	1.875	1.958	1.825	1.825	2.680	2.756	2.830	4.05	2.36
	260	1.804	2.038	2.127	2.000	2.000	2.920	2.985	3.070	4.39	2.56
	280	1.958	2.205	2.313	2.150	2.150	3.130	3.218	3.315	4.72	2.76
	300	2.106	2.374	2.478	2.320	2.320	3.375	3.461	3.565	5.07	2.95
	320	2.268	2.545	2.648	2.470	2.470	3.615	3.696	3.820	5.41	3.15
	340	2.416	2.717	2.836	2.625	2.625	3.840	3.941	4.065	5.74	3.35
	360	2.573	2.884	3.023	2.820	2.780	4.075	4.176	4.320	6.08	3.55
	380	2.732	3.066	3.198	2.980	2.980	4.346	4.424	4.560	6.42	3.74
	400	2.881	3.230	3.369	3.140	3.130	4.560	4.666	4.825	6.77	3.94
	420	3.055	3.421	3.568	3.300	3.300	4.800	4.914	5.080	7.10	4.14
	440	3.218	3.595	3.748	3.470	3.470	5.045	5.154	5.340	7.44	4.34
	460	3.384	3.784	3.944	3.650	3.650	5.335	5.408	5.600	7.77	4.53
Vacuum Inches of Hg	480	3.556	3.955	4.128	3.800	3.800	5.540	5.651	5.925	8.11	4.73
	500	3.720	4.151	4.325	4.000	4.000	5.800	5.906	6.120	8.44	4.92
	520	3.893	4.342	4.525	4.150	4.150	6.050	6.148	6.380	8.78	5.12
	540	4.063	4.525	4.714	4.340	4.340	6.320	6.410	6.650	9.13	5.32
	560	4.238	4.715	4.905	4.500	4.500	6.572	6.640	6.920	9.46	5.52
	580	4.414	4.906	5.116	4.640	4.640	6.835	6.919	7.170	9.80	5.71
	600	4.598	5.102	5.303	4.850	4.850	7.100	7.184	7.440	10.14	5.91
	620	4.769	5.292	5.508	5.020	5.020	7.370	7.432	7.715	10.49	6.11
	640	4.955	5.482	5.698	5.180	5.180	7.630	7.698	7.980	10.82	6.30
	660	5.133	5.686	5.915	5.350	5.350	7.900	7.949	8.240		6.50
	680	5.315	5.875	6.108	5.550	5.550	8.170	8.196	8.515		6.70
	700	5.502	6.084	6.329	5.700	5.700	8.425	8.472	8.780		6.89
Vacuum Inches of Hg	720	5.681	6.280	6.521	5.900	5.900	8.670	8.708	9.050		7.09
	740	5.879	6.490	6.747	6.040	6.040	8.932	8.999	9.324		7.29
	760	6.073	6.688	6.948	6.280	6.280	9.220	9.256	9.600		7.49
	780	6.262	6.901	7.162	6.480	6.480	9.480	9.532	9.950		7.68
	800	6.460	7.105	7.356	6.680	6.680	9.750	9.788	10.150		7.88
	820	6.652	7.319	7.605	6.890	6.890	10.020	10.068	10.425		8.08
	840	6.843	7.517	7.800	7.090	7.090	10.270	10.308	10.670		8.28
	860	7.049	7.743	8.043	7.300	7.300	10.540	10.610	11.050		8.47
	880	7.248	7.953	8.248	7.500	7.500	10.820	10.971	11.425		8.67
	900	7.452	8.168	8.487	7.720	7.720	11.075	11.156	11.550		8.86
	920	7.668	8.400	8.715	7.950	7.950	11.350	11.421	11.825		9.09
	940	7.862	8.610	8.937	8.140	8.140	11.620	11.707	12.150		9.26
Vacuum Inches of Hg	960	8.073	8.830	9.148	8.350	8.350	11.900	11.976	12.420		9.46
	980	8.279	9.051	9.395	8.550	8.550	12.150	12.269	12.720		9.65
	1000	8.490	9.276	9.624	8.750	8.750	12.432	12.543	13.080		9.85

(N)TS25 Series - Thor-Sight™ Flow Indicator



Thor-Sight™ A Better Sealing Method

Thorburn's Thor-Sight™ offers two types of seals between the body and the outside diameter of the glass lens. For lower temperature applications an elastomer radial seal is used where as in higher temperatures a PTFE lip seal is used. Both seals house stainless steel spring that maintains a constant expanding force within the seal to form a longer lasting, more secure seal

Thor-Sight™ Applications

POWER PLANTS Monitor flow of critical fluids, such as lubricants pumped to turbines in hydro-electric generators and water cooling lines

ELIMINATING STEAM BETWEEN LINE EROSION Wet steam combined with fly ash and dirt form a high velocity abrasive compound. Thor-Sight™ can show when filters begin to fail, when traps become clogged or worse, the abrasive steam will pass through the sight flow indicator.

MONITORING CLOGGED FILTERS Sight flow indicators are usually installed before and after a filter trap to monitor the filtration efficiency

MONITORING PROGRESS AND PURGE The bidirectional flapper shows flow direction.

There are four critical ways to view the media to increase productivity and reduce process maintenance costs...

Thor-Sight™ Indicator Options



Propeller The best way to show flow of opaque liquids. Ideal for observations at a distance. Flow from right to left is standard. Specify if left to right flow is needed.



Bi-Directional Flapper This bi-directional indicator points in either direction to show you at a glance which way the liquid is flowing.



Drip Tube Ideal for gravity, extremely low or intermittent flow. Keeps product from dripping on the glass. Assures constant see-through. For vertical lines.



Bi-Directional Plain When the color and clarity of your liquid are of prime importance.

ITEM	(N)TS25
Max. Pressure @ Temperature	250 PSI @ 175°F / 1.7 MPa @ 79°C
Max. Temperature @ Pressure	150 PSI @ 500°F / 1.0 MPa @ 260°C
Glass	Tempered Borosilicate
Seals	Viton A*
Indicator Material	Ryton**

* Other seals available upon request | ** PTFE is available upon request

How To Order Thor-Sight™ Model (N)TS25

Model	Material	Size ID	End	End	Indicator	Seal
(N)TS25	S6	32	T	MJ	2	D
	S6 = 316SS* X = Other (Specify)	Hose size in 1/16 of an inch Examples: 04=1/4 32=2 06=3/8 48=3 08=1/2 64=4 12=3/4 96=6 16=1 128=8 20=1 1/2 160=10 24=1 1/2 192=12	F = Flanged ANSI Class 150 T = Female NPT B = Butt Weld S = Socket Weld MJ = Male JIC MP = Male NPT FJX = Female JIC Swivel XX = End 1 Specify YY = End 2 Specify		0 = Plain 1 = Propeller 2 = Flapper 3 = Drip Tube 4 = Low Flow	D = Buna N I = Viton C = Neoprene H = EPDM J = PTFE X = Other (Specify)

Notes: Prefix (N) is used for code compliance. When Nuclear Class 2, 3 or 4 is required insert NC2 for Class 2 NC3 for Class 3 & NC4 for Class 4 at the end of the part number. Nuclear Class 6 leave blank.

(N)BC Series - Big Cam™ Camlock Flanged Couplings

“Make leakproof flange connections in seconds!”

Thorburn’s Big Cam™ is used anywhere there is a need to rapidly connect and disconnect piping or hose. Impossible to loosen while pressure is in the line. Couplings are hydrostatically tested and leakproof at 450 psi (31 bar). ANSI B16.5 Class 150 flanges are standard.



Features & Benefits

- Tough, long lasting and vibration proof
- Designed for industrial & marine service
- Recessed O-Ring replaces conventional flange gaskets providing a positive leak proof seal
- Compatible with all international flange standards, ANSI 150, 300, 600, B.S. Table E DIN PN10, 16, 25, 40, JIS, etc.
- Available in sizes from 3” to 28”



Traditional flanged bolted connection

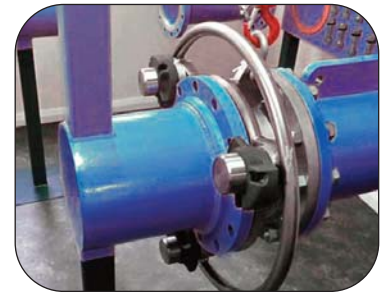

Thorburn Big Cam™ quick flanged connection

Thorburn Part Number	Nominal Pipe Size	Flange OD 150lbs ANSI	Flange Thickness	Seal ID	Number of Cams	Minimum Locking Range	Maximum Locking Range	Number of Studs	Stud Dimensions	Weight (lbs)
(N)BC48*XY	3	7 1/2	15/16	4	2	5/8	1 1/8	4	5/8 X 2 5/8	20
(N)BC64*XY	4	9	15/16	4	2	5/8	1 1/8	4	5/8 X 2 5/8	42
(N)BC80*XY	5	10	15/16	6 5/16	2	11/16	1 3/16	8	3/4 X 2 3/4	45
(N)BC96*XY	6	11	1	7 5/16	2	3/4	1 1/4	8	3/4 X 2 3/4	48
(N)BC128*XY	8	13 1/2	1 1/8	9 1/16	3	7/8	1 3/8	8	3/4 X 2 3/4	74
(N)BC160*XY	10	16	1 3/16	11 9/16	3	15/16	1 7/16	12	7/8 X 3 1/4	86
(N)BC192*XY	12	19	1 1/4	13 3/8	4	1	1 1/2	12	7/8 X 3 1/4	122
(N)BC224*XY	14	21	1 3/8	15	4	1 1/8	1 5/8	12	1 X 3 3/4	150
(N)BC256*XY	16	23 1/2	1 7/8	16 15/16	5	1 3/16	1 11/16	16	1 X 4 1/4	186
(N)BC320*XY	20	27 1/2	1 11/16	21 1/2	6	1 7/16	1 15/16	20	1 1/8 X 4 3/4	252
(N)BC384*XY	24	32	1 15/16	25 1/2	7	1 11/16	2 3/16	20	1 1/4 X 5 1/2	303
(N)BC448*XY	28	35 1/2	2 1/16	29 1/4	9	1 11/16	2 7/16	28	1 1/4 X 6	371

*** Material Codes**

X Specify Coupling Material - A = Aluminum, CS = Carbon Steel, S6 = 316 Stainless Steel

Y Specify Gasket Material - D = Buna N, N = Neoprene, H = EPDM, J = PTFE, I = Viton

Note: 150lbs flanges are standard. For 300lbs ANSI Flange insert suffix 3 at the end of ordering code (also available in European and DIN Classes) insert suffix PN10, PN16, PN25 at the end of ordering code

Part Number Example & Description

(Part number must follow the order listed below)

Example 1

BC48-S6-H-3

Example 2

BC48-S6-H-PN25

Example 1

BC48 | Big Cam 3 inch pipe size

S6 | Material: 316SS

H | Gasket Material: EPDM

3 | 300 lbs ANSI Flange

Example 2

BC48 | Big Cam DIN80 pipe size

S6 | Material: 316SS

H | Gasket Material: EPDM

PN25 | PN25 Flange

Notes: Prefix (N) is used for code compliance. When Nuclear Class 2, 3 or 4 is required insert NC2 for Class 2, NC3 for Class 3 & NC4 for Class 4 at the end of the part number. Class 6 use prefix (N) only

(N)T92H Series - Dry Break Quick Coupling

Prevents Resin Valve Blockage & Disconnection Spillage

The (N)T92H is a major advancement in quick coupling technology achieving unrestricted full flow during operation and drip free double shut-off drybreak disconnection. The (N)T92H environmentally focused quick coupling system is specifically designed to prevent chemical spills, reduce vapor emissions of volatile organic compounds (VOCs) and enhance operator safety. Its full flow smooth bore design means better flow even for highly viscous fluids.

The (N)T92H coupling system consists of a female end having a concave ball valve and a male end having a convex ball valve that are precision machined to eliminate any spaces between the ball valves. A quarter turn of the ball valve securely seals the process fluids within the line. The (N)T92H coupling can even provide a seal when solids are suspended in the media such as radioactive D₂O resins in PHWR nuclear power station.

Thorburn's (N)T92H has a built in swivel end that eases alignment regardless of pipe or hose orientation and has a unique locking mechanism that prevents accidental spillage. It is ideally suited for tank truck and tank car transfer systems where environmental compliance is not an option and operator safety is a company culture.

Features

- **Zero spillage** during disconnection eliminates hazardous chemical waist pollution even when solids are suspended in the media.
- **Unrestricted high flow** during operation reduces pressure drops.
- **Eliminates chemical waste** incineration and disposal costs.
- **Reduces liability exposure**, loss time and worker comp claims.
- **Built in swivel** eases alignment regardless of hose orientation.
- **Protects the installation assets** from hazardous waste product.
- **Prevents radio active D₂O resin blockage** between the valves in a PHWR nuclear power station.

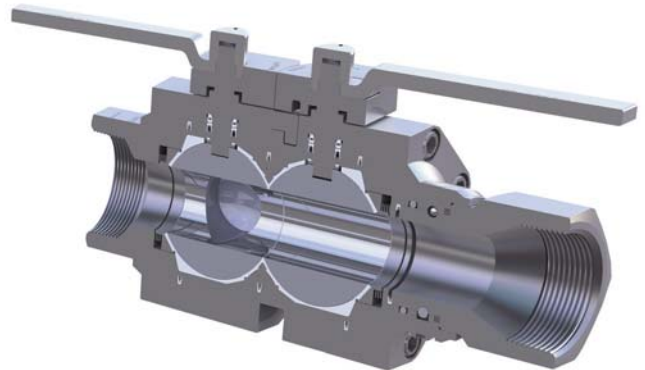

Unrestricted full flow reduces pressure drop during operation

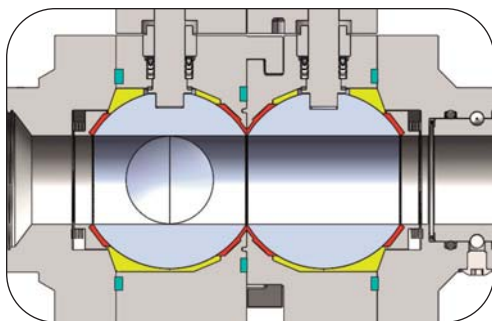

(N)T92H Sealing Technology

Cavity Filler - Prevents flow accumulation between ball valve and coupling body. Reduces spillage when disconnecting and prevents solids from being trapped between the rotating ball valves.

Ball Valve Seal - Flexible arch shaped ball valve seal provides constant sealing pressure and compensates for machining tolerances.

Spring Enhanced O-Ring Seal - Puts constant pressure around the stem and eliminates leaks through the valve handle stem.



Cavity Filler



Ball Valve Seal

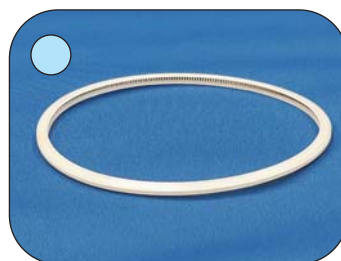

Spring Enhanced O-ring Seal

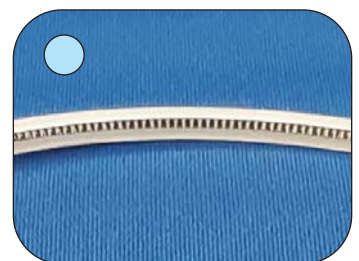

Detail of The Spring in the O-ring Seal

(N)T92H Built In Safety Features

Thorburn Flex (N)T92H is a dry break, zero leak, quick coupling, with mating convex and concave ball valves on each side of the coupling. The (N)T92H unique design features provides up to five levels of independent safety mechanisms to prevent spills and accidental release of dangerous contaminants in the environment. The safety features are based on a combination of locking mechanisms that prevent wrong operation of the coupling by allowing only the preset sequential operation.



- **Ball Valve Zero Gap System** (Convex (male end) & Concave (female end)) prevents hazardous chemical loss during disconnection.
- **Valve Handle Locking System** locks the handle in the off position to safeguard against accidental opening when disconnected.
- **Safety Locking Mechanism** incorporates a Valve Handle Safety Locking Pin to prevent accidental openings.
- **The Locking Pin** is guided by the Valve Handle on the male end coupler into the **Locking Pin Slot** on the female end coupler.
- **Locking Pin Slot** (female end) locks the coupling halves together and protects against accidental disconnection during operation.

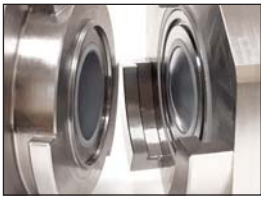

Ball valve "Zero Gap" system



Valve handle locking system



Safety Locking Mechanism



Locking Pin



Locking Pin Slot

(N)T92H Performance Characteristics

Adapter/Coupler Size		End Size		Spillage	Maximum Emissions	Flow Rate		Max. Working Pressure (min. 4-1 Safety)		Weight				Temperature			
										Male		Female		Min		Max	
in	mm	in	DIN	cc	ppm	GPM	l/min	psi	bar	lb	kg	lb	kg	°F	°C	°F	°C
1	25	3/4, 1	20, 25	< 0.1	< 25	60	227	3000	207	4.02	1.82	4.23	1.92	-459	-273	400	204
2	50	1 1/2, 2	40, 50	< 0.2	< 25	180	681	1800	124	17.45	7.92	17.44	7.91	-459	-273	400	204
3	80	3	80	< 1	< 25	350	1325	1000	69	33.70	15.2	30.65	13.9	-459	-273	400	204

(N)T92H For Cryogenic Unloading

Thorburn's (N)T92H series is the worlds first dry break full flow coupling used for liquid cryogenic loading/unloading service. A dramatic innovation over the poppet style cryogenic coupling which has inherent spillage when disconnected. The (N)T92H coupling has an easy turn action to connect and start the product flow. The full unrestricted flow will dramatically increase loading & unloading productivity of cryogenic liquids. The dry break technology will protect the environment and the operator's safety.

Applications

- Transfer of LIN/LOX/LAR, CO₂, Nitrous Oxide & LNG
- Loading/unloading of tank trucks, rail tankers
- Container discharge
- Fuel bunkering
- Vapor recovery lines

Advantages

- Easy push & turn connection
- The valves cannot be opened when coupling is disconnected
- The coupling cannot be disconnected when the valves are open
- Reliable dry break with poppet valves



Thorburn's NT92H dry break couplings ideal for cryogenic LNG tank truck loading/unloading. Available with tank truck & railcar flanges

Problematic Quick Disconnect Coupling Technologies



Cam & Groove Type = Spillage

Cam and Groove type couplings are incapable of avoiding spillage and vapor leakage upon disconnection. They are prone to accidental disconnects which can be expensive and extremely hazardous.



Ordinary Ball Valves Added = Spillage

Ordinary Ball Valves added to quick couplings to shut off the flow allow trapped liquid between the hose and the adapter to flow freely on to your plants floor or your employees hands upon disconnection.



Traditional Poppet Valves = Spillage

Traditional two-way poppet valve style dry break couplings by its very design are predisposed to spills because of the unavoidable liquid that is trapped in the gap between the coupler poppet valve and the adapter poppet valve upon disconnection.

(N)T92H Easy to Operate Dry Break Solution

The (N)T92H coupling has an easy turn action to connect and start the product flow. The valves will not open until both coupling halves are connected properly. The coupling halves are first aligned and then connected with a push, followed by a quarter turn. There are no threads to damage by over tightening and no failure prone cam and groove latch connections to secure. The coupling halves are independent "shut off" ball valves that are controlled manually by rotating the valve handles in a specific sequence.



Align coupling halves



Push together & turn 90°

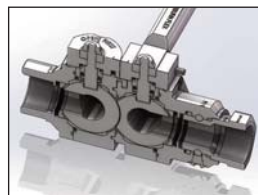

Coupling connected & locked

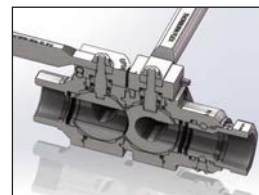

Open male end valve

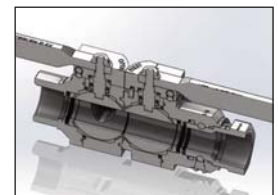

Open female end valve

The (N)T92H can only be disconnected when both the valves are shut off in sequence; female end valve first and then male end valve second. This ensures zero spillage and protects against accidental disconnection.

How To Order (N)T92H Series Dry Break Coupling

Model	Valve Size	Type	Body Material (Wetted Parts)	End Size	1st End	2nd End	Seal	Options
(N)T92H	16	0	S6	32	1	1	1	DC
	16 = 1" (DN 25) 32 = 2" (DN 50) 48 = 3" (DN 80)	C = Coupler (Socket) N = Plug (Nipple)	S6=SA 479 type 316SS, EN1.4404 S5=SA 564 type 630 EN1.4548 H16=Hasteloy SB574 type C276 EN2.4819	12 = 3/4" (DN 20) 16 = 1" (DN 25) 24 = 1 1/2" (DN 40) 32 = 2" (DN 50) 48 = 3" (DN 80)	1=FNPT 2=FBSP 3=O-Seal 4=SCH 40 Butt Weld 5=SCH 80 Butt Weld 6=ANSI 150# Flange 7=ANSI 300# Flange 8=ANSI 600# Flange 9=PN10 Flange 10=PN16 Flange 11=PN25 Flange 12=PN40 Flange	13=Sanitary Flange 14=Tank Truck Flange XX=Specify YY=Specify	1=UMHW 2=PTFE 3=PEEK	H = Handle DC = Dust Cap XX = Specify

(N)T52 Series - Non-Valved Full Flow Cryogenic Couplings

Thorburn's (N)T52 Series cryogenic quick coupling system is designed, engineered & manufactured to provide safe, reliable, leak tight quick connect & disconnect for cryogenic fluids. Thorburn's (N)T52 is an ideal quick coupling to replace threaded union type connectors where speed and convenience is a requirement. The (N)T52 standard seals are made of UHMW polyethylene.

Features & Benefits

Ball Bearing Locking Mechanism

- Multiple ball bearings for better load distribution
- Live swivel to eliminate torsion load
- Facilitates alignment during connection

Extended Sleeve Holder

- Larger gripping space

Compression Spring

- Automatically returns the sleeve to its original position

Standard UHMW Polyethylene Seal

- Ideal for liquid nitrogen service

Ultrasonic Cleaning

- Removes contaminants & minimizes frost build up

Quality & Design

- Full traceability of all pressure retaining components
- CRN for all Canadian Provinces

Benefits of UHMW PE Seal

(Ultra High Molecular Weight Polyethylene)

- Low temperature -459.67°F (-273.15°C) without material degradation
- Self-lubricated material with low coefficient of friction, that reduces force required to connect / disconnect coupling halves
- High impact strength and abrasion resistance that outwears carbon steel 10 to 1
- Good chemical resistance to organic solvents, de-greasing agents and electrolytic attack.
- Very low moisture absorption that prevents ice formation when used for low temperature fluids

How To Order (N)T52 Series Couplings

Model	Size ID	Body Type	Coupler	Size	End	Seal	Material
NT52	08	P	C	08	F	U	S6
	Hose size in 1/16 of an inch Examples: 01 = 1/16 02 = 1/8 04 = 1/4 06 = 3/8 08 = 1/2 12 = 3/4 64 = 4 etc.	P = Straight Through Options: SL = Sleeve Lock Place suffix "SL" at end of part number	C = Coupler (Socket) N = Plug (Nipple)	Hose size in 1/16 of an inch Examples: 01=1/16 02=1/8 04=1/4 06=3/8 08=1/2 12=3/4 64=4 etc.	M = Male NPTF F = Female NPTF	B = Buna N V = Viton N = Neoprene E = EPDM T = PTFE Z = High Temp PTFE X = Other (Specify)	S6 = 316SS



Temperature ranges down to -269°C (452°F)

Working Pressure & Force To Connect

SIZE (inch)	3/8	1/2	3/4	1	1 1/2	2
Working Pressure (psi)*	500	500	500	500	150	150
Force To Connect (lbs)	2	2	4	5	7	10

* Maximum working pressure is base on a 4:1 safety factor. Higher pressures available.

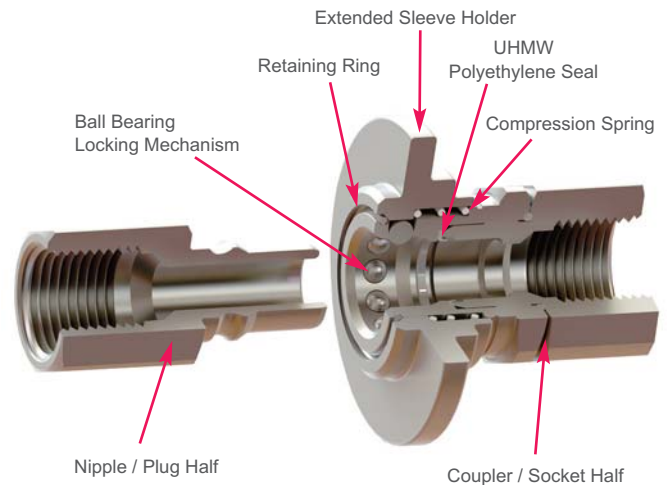

MT3TL Series - Met-O-Seal



Thorburn Met-O-Seal with looped handles



Tanker Truck/Car Loading Quick Coupling

Thorburn's Met-O-Seal Series MT3TL is an all purpose lightweight tanker loading/unloading quick coupling designed for leakproof operation as it cycles through a wide range of temperatures. The design offers a non restrictive flow with no variation in pipe diameter, leak proof operation with cryogenic liquids (LN2, LOX, LH2) and gaseous service.



Tanker truck cryogenic bottom loading station

Features

- Designed for use with liquids or gases from ambient to cryogenic
- Repeatedly reusable low temperature metal to metal seal
- Vents residual pressure prior to complete uncoupling
- Light torque when tightening by hand or wrench to working pressure
- Easily disconnected at cryogenic temperatures, no frost balling
- Reusable primary metal to metal wedge seal
- Thermal cycling compensation

Thorburn Number	Nominal Size		Working Pressure		Minimum Length	
	(in)	(mm)	(psi)	(bar)	(in)	(mm)
MT3TL16XYM	1	25	2400	165	3.00	80
MT3TL24XYM	1 1/2	38	2200	152	3.75	95
MT3TL32XYM	2	50	2000	138	4.00	102
MT3TL48XYM	3	80	1200	83	5.50	140
MT3TL64XYM	4	100	750	52	5.50	140

End Codes - X = Left End, Y = Right End,

1=Female thread (NPT), 2=Male thread (NPT), 3=Butt weld, 4=Socket weld female

Body Material Codes - M

C = Carbon Steel (SA105), C1 = Carbon Steel (SA350-LF2), AL = Aluminum
S4 = 304SS, S6= 316SS, I12 = Alloy 825, H16 = Hastelloy C276, XX= Specify

External Sleeve Material Codes

AL = Aluminum, S6 = 316SS, C = SA105, C1 = SA350-LF2

Options

LH = Loop handle sleeve (handle material is same as external sleeve)

Part Number Example & Description

(Part number must follow the order listed below)

MT3TL-32-1-4-C-N-S6-LH

Technical

- Leak rates (when connected) <1 x 10⁻⁹ std. cc. He/S.
- Full vacuum to 5,000psi, Cryogenics to 1500°F
- Backup seal temperature rating:
PTFE -273°C (-459°F) to 204°C (400°F) **Code: J**
HNBR -40°C (-40°F) to 150°C (300°F) **Code: N**
FKM -40°C (-40°F) to 175°C (350°F) **Code: I**
- Designed and tested to ASME B31.1 & B31.3
- All stainless steel are nitrated to reduce galling

MT3TL	Met-O-Seal Model MT3TL (3 pieces)
32	Size: 2 inch
1	Left End: Female Thread (NPT)
4	Right End: Socket Weld Female
C	Material: Carbon Steel (SA105)
N	Backup Seal Material: HNBR
S6	External Sleeve Material: 316SS
LH	Loop Handle Sleeve (316SS)

MTS4 Series - Met-O-Seal



Applications

Nuclear Generating Plant:

- a) Core feeder piping freezing systems LN2 is used to freeze water in the piping during pipe inspection. Met-O-Seal couplings are the cryogenic quick coupling
- b) Ion exchangers "Met-O-Seal" replace conventional flanges to allow wrench free operation
- c) Steam piping system high temperature/pressure (up to 800°F / 3000 psi)

High vacuum systems:

Composite building autoclave quick coupling

Cryogenics liquids & elusive gases:

LN2, LOX, LH2, H12, etc.

Technical

- Leak rates (when connected) <1 x 10⁻⁹ std. cc. He/S.
- Full vacuum to 5,000psi, Cryogenics to 1500°F
- Backup seal temperature rating:
 - PTFE -273°C (-459°F) to 204°C (400°F) **Code: J**
 - HNBR -40°C (-40°F) to 150°C (300°F) **Code: N**
 - FKM -40°C (-40°F) to 175°C (350°F) **Code: I**
- Designed and tested to ASME B31.1 & B31.3
- All stainless steel are nitrated to reduce galling
- Light torque when hand tightening to rated pressures

Part Number Example & Description

(Part number must follow the order listed below)

MTS4-16-1-4-C-BR-J-AL

MTS4	Met-O-Seal Model MTS4 (4 pieces)
16	Size: 1 inch (DIN 25)
1	Left End: Female Thread (NPT)
4	Right End: Socket Weld Female
S6	End Material: Stainless Steel (316SS)
BR	Ferrule Seal Material: Brass
J	Backup Seal Material: PTFE
AL	External Sleeve Material: Aluminum

Quick Couplings Cryogenic Liquids & Elusive Gases

Thorburn's Met-O-Seal Series MTS4 is a unique, thermally active quick coupling system specifically designed for leak proof make and break connections for operation with cryogenic liquids (LN2, LOX, LH2) and gaseous service. The reusable ferrule seal is made from different materials with different thermal and hardness properties than the coupling ends. Therefore, the seal is strengthened when changes in temperature occur.



Thorburn's Met-O-Seal Series MTS4 hose coupling used for loading liquid helium in an MRI machine at -269°C (-452°F) just above absolute zero. Magnets at that temperature lose all electrical resistance and become superconducting thus produce the same magnetic field for a thousand years with no more power required.

Thorburn Number	Nominal Size		Working Pressure		Minimum Length	
	(in)	(mm)	(psi)	(bar)	(in)	(mm)
MTS416XYM	1/4	6	5000	345	2.5	63.5
MTS424XYM	3/8	10	5000	345	2.5	63.5
MTS432XYM	1/2	12.7	4800	330	2.5	63.5
MTS448XYM	3/4	19	4600	317	2.75	70
MTS464XYM	1	25	4000	276	2.75	70
MTS464XYM	1 1/2	38	3800	262	3.5	90
MTS464XYM	2	50	3600	248	4.5	114
MTS464XYM	3	80	3200	221	5.5	140
MTS464XYM	4	100	3000	207	5.5	140

End Codes - X = Left End, Y = Right End

1=Female thread (NPT), 2=Male thread (NPT), 3=Butt weld, 4=Socket weld female

Body Material Codes - M

C = Carbon Steel (SA105), C1 = Carbon Steel (SA350-LF2), AL = Aluminum
S4 = 304SS, S6= 316SS, I12 = Alloy 825, H16 = Hastelloy C276, XX= Specify

Ferrule Seal Material Codes

AL = Aluminum, BR = Brass

External Sleeve Material Codes

AL = Aluminum, S6 = 316SS

Options

LH = Loop handle sleeve (handle material is same as external sleeve)

(N)UO Series - O-Seal™ Never Leak Pipe Unions



Features

- Never needs retightening, no maintenance
- Won't vibrate loose even under extreme vibration or pressure surges
- Unlimited brake/remake
- Hand tight pressures to 200 bar
- Flat face construction, easy slip in & out
- Dielectric insulating unions prevent galvanic corrosion deterioration
- Hammer Lug Nut for fast make and break
- Ideal union to seal Oxygen, Nitrogen
- 3000, 6000 & 9000 psi ratings available

Technical Data

- Materials: SA105 Carbon Steel, SA182 Type 316. Option SA350LF2, Hastelloy, Inconel
- ASME B31.1, B31.3 & ANSI B16.11 forged steel fittings

Thorburn O-Seal™ Unions are recommended where piping requirements dictate the necessity of having a flat face seat to make and break the pipeline or when leaky metal-to-metal seat unions are unacceptable. Thorburn's O-Seal™ Unions are designed to comply with current industry standards for pressure piping. These standards include ANSI B31.1 "Power Piping", ANSI B16.11, MSS SP83 "Forged Steel Fittings Socket Welded & Threads" and ASME "Boiler & Pressure Vessel Code".

Traditional metal to metal union sealing surfaces rust when they are stored outside and are exposed to humidity. When this happens and installed in piping systems, it is inevitable that leaks will occur and it doesn't matter how much torque is applied to stop the leaks, the traditional metal to metal unions will continue to leak. This becomes an extremely frustrating experience for contractors, EPCs and owners especially when it occurs during project commissioning and testing.

Thorburn's O-Seal™ Unions are an excellent alternative to metal to metal seat unions because they are dimensionally similar to the MSS SP83 forged union and will not leak because the seal is made on the O-Ring not on the metal to metal seat like traditional unions.



Won't vibrate loose even under extreme vibration or pressure surges

Don't settle for leaky metal on metal sealing pipe unions



3000 lb MSS SP83 forged union with rusted sealing surfaces leaking with no pressure in the piping line. Once the sealing surfaces are rusted or compromised, they will always leak no matter how much torqued is applied



Thorburn's O-Seal (blue) 3000 lb union uses an elastomeric seal that compensates and seals on any compromised surfaces no matter how rusted or scratched

Metallic Hose Assemblies | Quick Couplings



Thorburn O-Seal™ assembled female threaded union with handle bar lug nuts

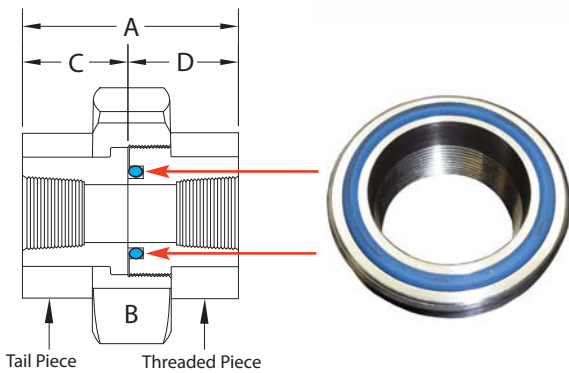

Nominal Size		A Overall Length		B Hex		C Tail Piece		F Thread Piece	
(in)	(mm)	(in)	(mm)	(in)	(mm)	(in)	(mm)	(in)	(mm)
1/8	3	1.660	42	1 3/8	35	0.785	20	0.875	22
1/4	6	1.660	42	1 3/8	35	0.785	20	0.875	22
3/8	10	1.800	46	1 1/2	38	0.875	22	0.935	24
1/2	12.7	2.035	52	1 7/8	48	0.935	24	1.100	28
3/4	19	2.148	55	2 1/8	54	1.023	26	1.125	32
1	25	2.570	65	2 1/2	64	1.258	32	1.312	33
1 1/4	32	2.822	72	3	80	1.385	35	1.437	37
1 1/2	38	3.072	78	3 3/8	86	1.510	38	1.562	40
2	50	3.259	83	3 7/8	98	1.572	40	1.687	43
2 1/2	64	3.635	92	4 7/8	124	1.760	45	1.875	48
3	80	4.135	105	5 1/2	140	2.010	51	2.125	54

Note: millimeters have been rounded

How to Order (N)UO Series Pipe Unions

UNION TYPE	TAIL PIECE CODES	THREAD PIECE CODES	SIZE CODES	CLASS CODES	O-RING CODES*	BODY MATERIAL CODES	OPTIONS*
(N)UO	FP	FP	02 (1/8)	1 = 3000 lbs	D = BUNA N** J = PTFE H = EPDM I = FLUOROCARBON (VITON)*	CS = A105** S4 = 304SS** S6 = 316SS** H = HASTELLOY I = INCONEL M = MONEL	O = ORIFICE D = DIELECTRIC INSULATED H = HANDLE BAR LUG NUT
	MP	MP	04 (1/4)	2 = 6000 lbs			
	SP	SP	06 (3/8)				
	ST	ST	08 (1/2)				
	BW	BW	12 (3/4)				
CODE DESCRIPTIONS			16 (1)				
Union Type Code (N)UO=O-Seal Union			20 (1 1/4)				
End Type Codes FP=FNPT Pipe MP=MNPT Pipe SP=Socket Weld Pipe ST=Socket Weld Tube BW=Butt Weld Pipe			24 (1 1/2)				
			32 (2)				
			40 (2 1/2)				
			48 (3)				
					* Only Applicable to O-Seal Unions	** Standard Material	* Only Applicable to O-Seal Unions

Part Number Example & Description

(Part number must follow the order listed below)

UO-FP-FP-16-1-H-S6-D

UO	O-Seal Union
FP	Tail Piece - Female FNPT Pipe
FP	Thread Piece - Female FNPT Pipe
16	Size 1 inch
1	3000 lbs Class
H	EPDM O-Ring Material
S6	Stainless Steel Material
D	Dielectric Insulation Option

Notes: Prefix (N) is used for code compliance. When Nuclear Class 2, 3 or 4 is required insert NC2 for Class 2 NC3 for Class 3 & NC4 for Class 4 at the end of the part number. Nuclear Class 6 leave blank.

Guard-Lok™ Series - Camlock Quick Couplings

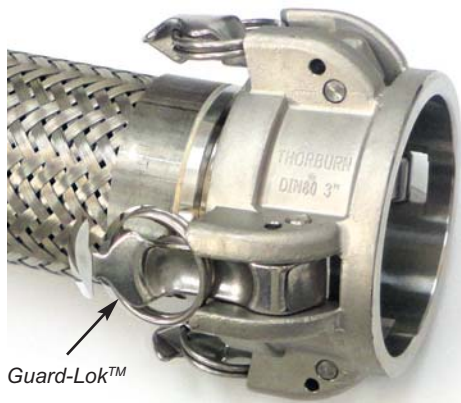

Guard-Lok™

Thorburn 733C-HD High Pressure Coupler with 4 automatic Guard-Lok™ locking levers

Thorburn's Camlock Quick Couplings with Guard-Lok™ Technology

Simple Connect/Disconnect Secured Sealing

Thorburn's Camlock Guard-Lok™ Coupling Series have mechanism built into the levers which prevent accidental disconnection during operation. The coupling levers lock themselves automatically into the coupler body in the closed position and stay locked until opened manually. Ideal for applications where vibration is present, hose assemblies are dragged or the coupling could be accidentally opened.

Guard-Lok™ Advantages

- Locks shut with one smooth motion
- Levers automatically lock to the body when closed
- Prevents accidental disconnection during operation



Thorburn's PTFE Encapsulated Rubber Gasket System

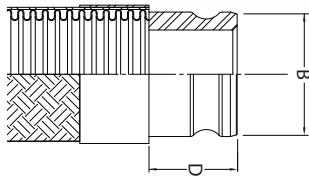

Male Camlock Hose End 633E

(Use prefix "N" only for ASME Code Applications)

Material: SA351 CF8M/SA479 T316 | Code: XX = S6 (316SS)

Pressure: 250 psi (2.5" ID or less), 150 psi (3" - 6" ID)

Part Number	Adapter/Coupler Size		Hose Shank Size		(B) Outside Diameter		(D) Exposed Length	
	in	mm	in	mm	in	mm	in	mm
(N)633E-XX-08	.5	13	.5	13	1.26	32	2.6	67
(N)633E-XX-12	.75	20	.75	20	1.26	32	2.6	67
(N)633E-XX-16	1.0	25	1.0	25	1.63	41	3.0	76
(N)633E-XX-20	1.25	32	1.25	32	2	51	3.5	89
(N)633E-XX-24	1.5	38	1.5	38	2.14	54	3.6	91
(N)633E-XX-32	2.0	50	2.0	50	2.64	67	4.0	102
(N)633E-XX-40	2.5	64	2.5	64	3.07	78	4.5	114
(N)633E-XX-48	3.0	76	3.0	76	3.70	94	4.75	121
(N)633E-XX-64	4.0	102	4.0	102	4.71	120	5.0	127
(N)633E-XX-96	6.0	152	6.0	152	7.10	180	6.7	170

Code: XX = S6 (316SS)

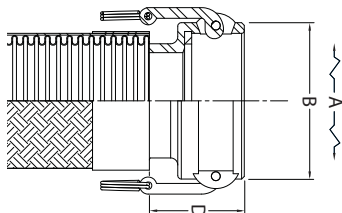

Female Camlock Coupler Hose End 733B/633B

(Use prefix "N" only for ASME Code Applications)

Material: SA351 CF8M/SA479 T316 | Code: XX = S6 (316SS)

Pressure: 250 psi (2.5" ID or less), 150 psi (3" - 6" ID)

Gasket Material: Buna-N (Standard) Options: EPDM, FKM & PTFE Encapsulated Rubber (ER)

Temperature: Buna-N, EPDM (250°F), FKM, PTFE (ER) (210°F)

Part Number	Adapter/Coupler Size		Hose Shank Size		(A) O.D. Extended Cam Arms		(B) Outside Diameter		(D) Exposed Length	
	in	mm	in	mm	in	mm	in	mm	in	mm
(N)733C(633C)-XX-Y-08	.5	13	.5	13	4.51	115	2.11	54	2.4	61
(N)733C(633C)-XX-Y-12	.75	20	.75	20	4.51	115	2.11	54	2.4	61
(N)733C(633C)-XX-Y-16	1.0	25	1.0	25	5.10	130	2.44	62	2.8	71
(N)733C(633C)-XX-Y-20	1.25	32	1.25	32	6.86	174	3.26	83	3.14	80
(N)733C(633C)-XX-Y-24	1.5	38	1.5	38	7.16	182	3.56	90	3.35	85
(N)733C(633C)-XX-Y-32*	2.0	50	2.0	50	7.54	192	3.94	100	3.75	95
(N)733C(633C)-XX-Y-40	2.5	64	2.5	64	8.03	204	4.43	113	4.0	102
(N)733C(633C)-XX-Y-48*	3.0	76	3.0	76	9.56	243	5.46	139	4.3	109
(N)733C(633C)-XX-Y-64*	4.0	102	4.0	102	10.56	271	6.56	167	4.5	114
(N)733C(633C)-XX-Y-96*	6.0	152	6.0	152	16.26	413	10.16	258	6.0	152

Note: * Sizes for 733C-HD Only. When ordering 633C, pressures are less than shown above | Part Number Material Codes: XX = S6 (316SS)
Part Number Gasket Codes: Y = D (Nitrile), H (EPDM), I (FKM), PTFE Encapsulated Rubber Codes: JD (Nitrile), JH (EPDM), JI (FKM)



Female Camlock Adapter 633A

(Use prefix "N" only for ASME Code Applications)

Material: SA351 CF8M/SA479 T316 | Code: XX = S6 (316SS), AL (Aluminum)

Pressure: 250 psi (2.5" ID or less), 150 psi (3" - 6" ID) - Stainless Steel Only

Thread Size: Standard NPT Optional: Use Code ZZ & Specify (BSP, BSPT, DIN, JIS)

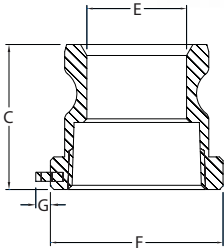

Part Number	Adapter Size		Thread Size		(C) Overall Length		(E) Inside Diameter		(F) Across Corners		(G) Chain Lug Extension	
	in	mm	in	mm	in	mm	in	mm	in	mm	in	mm
(N)633A-XX-08	.5	13	.5	13	1.6	41	.53	13	1.12	28		
(N)633A-XX-12	.75	20	.75	20	1.62	41	.75	20	1.49	38		
(N)633A-XX-16	1.0	25	1.0	25	1.91	49	.88	22	1.76	45	.34	9
(N)633A-XX-20	1.25	32	1.25	32	2.16	55	1.04	26	2.19	56	.34	9
(N)633A-XX-24	1.5	38	1.5	38	2.29	58	1.35	34	2.44	62	.33	8
(N)633A-XX-32	2.0	50	2.0	50	2.54	65	1.72	44	2.92	74	.31	8
(N)633A-XX-40	2.5	64	2.5	64	2.75	79	2.14	54	3.49	89	.27	7
(N)633A-XX-48	3.0	76	3.0	76	2.84	72	2.8	71	4.22	107	.44	11
(N)633A-XX-64	4.0	102	4.0	102	3.16	80	3.78	96	5.41	137	.39	10
(N)633A-XX-96	6.0	152	6.0	152	3.35	85	5.90	150	7.70	196	.60	15

Code: XX = S6 (316SS), AL (Aluminum)



Male Camlock Adapter 633F

(Use prefix "N" only for ASME Code Applications)

Material: SA351 CF8M/SA479 T316 | Code: XX = S6 (316SS), AL (Aluminum)

Pressure: 250 psi (2.5" ID or less), 150 psi (3" - 6" ID) - Stainless Steel Only

Thread Size: Standard NPT Optional: Use Code ZZ & Specify (BSP, BSPT, DIN, JIS)

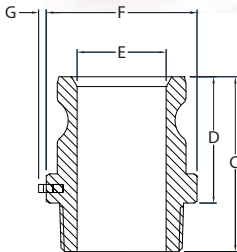

Part Number	Adapter Size		Thread Size		(C) Overall Length		(D) Exposed Length		(E) Inside Diameter		(F) Across Corners		(G) Chain Lug Extension	
	in	mm	in	mm	in	mm	in	mm	in	mm	in	mm	in	mm
(N)633F-XX-08	.5	13	.5	13	2.47	63	1.67	42	.56	14	1.42	36		
(N)633F-XX-12	.75	20	.75	20	2.47	63	1.67	42	.75	19	1.42	36		
(N)633F-XX-16	1.0	25	1.0	25	2.89	73	1.99	51	.85	22	1.75	45	.34	9
(N)633F-XX-20	1.25	32	1.25	32	3.23	82	2.23	57	1.04	26	2.16	55	.34	9
(N)633F-XX-24	1.5	38	1.5	38	3.29	84	2.31	59	1.34	34	2.44	62	.30	8
(N)633F-XX-32	2.0	50	2.0	50	3.57	91	2.57	65	1.72	44	2.84	72	.28	7
(N)633F-XX-40	2.5	64	2.5	64	4.18	106	2.78	71	2.14	54	3.45	88	.29	7
(N)633F-XX-48	3.0	76	3.0	76	4.37	111	2.87	73	2.80	71	4.07	103	.44	11
(N)633F-XX-64	4.0	102	4.0	102	4.79	122	3.19	81	3.78	96	5.27	134	.40	10
(N)633F-XX-96	6.0	152	6.0	152	5.20	132	3.40	86	5.84	148	7.70	196	.60	15

Code: XX = S6 (316SS), AL (Aluminum)



Socket Weld Camlock Adapter 633ASW

(Use prefix "N" only for ASME Code Applications)

Material: SA351 CF8M/SA479 T316 | Code: XX = S6 (316SS), AL (Aluminum)

Pressure: 250 psi (2.5" ID or less), 150 psi (3" - 6" ID)

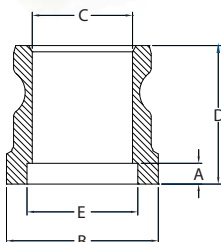

Part Number	Adapter Size		(A) Socket Depth		(B) Outside Diameter		(C) Inside Diameter		(D) Overall Length		(E) Socket Diameter Pipe Tube			
	in	mm	in	mm	in	mm	in	mm	in	mm	in	mm	in	mm
(N)633ASW-XX-08	.5	13	.30	8	1.00	25	.53	14	1.00	25	.88	22	.52	13
(N)633ASW-XX-12	.75	20	.30	8	1.25	32	.75	20	1.13	29	1.10	28	.77	20
(N)633ASW-XX-16	1.0	25	.30	8	1.45	37	.88	22	1.44	37	1.36	35	1.02	26
(N)633ASW-XX-20	1.25	32	.30	8	2.00	50	1.06	27	2.00	50	1.71	43	1.27	32
(N)633ASW-XX-24	1.5	38	.40	10	2.25	64	1.35	34	2.13	54	1.95	49	1.52	39
(N)633ASW-XX-32	2.0	50	.40	10	2.74	70	1.81	46	2.50	64	2.44	62	2.02	51
(N)633ASW-XX-40	2.5	64	.40	10	3.25	83	2.14	54	2.56	65	2.94	74	2.52	64
(N)633ASW-XX-48	3.0	76	.40	10	3.75	95	2.81	71	2.75	70	3.57	91	3.02	77
(N)633ASW-XX-64	4.0	102	.50	13	5.01	127	3.00	76	2.97	75	4.58	116	4.03	102
(N)633ASW-XX-96	6.0	152	.60	15	7.00	178	5.84	148	2.90	74	6.72	171	6.03	153

Code: XX = S6 (316SS), AL (Aluminum)

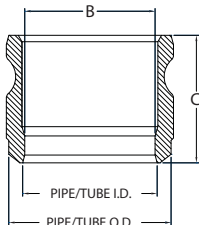

Butt Weld Camlock Adapter 633FBW

(Use prefix "N" only for ASME Code Applications)

Material: SA351 CF8M/SA479 T316 | Code: XX = S6 (316SS)

Pressure: 250 psi (2.5" ID or less), 150 psi (3" - 6" ID)

Part Number	Adapter Size		(C) Overall Length		(B) Inside Diameter	
	in	mm	in	mm	in	mm
(N)633FBW-XX-08	.5	13	1.43	36	.53	13
(N)633FBW-XX-12	.75	20	1.40	35	.75	19
(N)633FBW-XX-16	1.0	25	1.74	44	.88	22
(N)633FBW-XX-20	1.25	32	1.99	51	1.06	27
(N)633FBW-XX-24	1.5	38	2.06	52	1.25	32
(N)633FBW-XX-32	2.0	50	2.50	64	1.75	44
(N)633FBW-XX-40	2.5	64	2.44	62	2.14	54
(N)633FBW-XX-48	3.0	76	2.75	70	2.81	71
(N)633FBW-XX-64	4.0	102	2.88	73	3.75	95
(N)633FBW-XX-96	6.0	152	3.00	76	5.84	148

Code: XX = S6 (316SS)

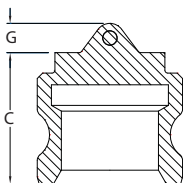

Camlock Plug Adapter 633DP

(Use prefix "N" only for ASME Code Applications)

Material: SA351 CF8M/SA479 T316 | Code: XX = S6 (316SS), AL (Aluminum)

Pressure: 250 psi (2.5" ID or less), 150 psi (3" - 6" ID) - Stainless Steel Only

Part Number	Adapter Size		(C) Overall Length		(G) Chain Lug Extension	
	in	mm	in	mm	in	mm
(N)633DP-XX-08	.5	13	1.06	27	.5	13
(N)633DP-XX-12	.75	20	1.41	36	.59	15
(N)633DP-XX-16	1.0	25	1.35	34	.96	24
(N)633DP-XX-20	1.25	32	1.94	49	.62	16
(N)633DP-XX-24	1.5	38	2.06	52	.50	13
(N)633DP-XX-32	2.0	50	1.90	48	.70	18
(N)633DP-XX-40	2.5	64	2.44	62	.81	21
(N)633DP-XX-48	3.0	76	2.03	52	1.0	25
(N)633DP-XX-64	4.0	102	2.10	53	1.0	25
(N)633DP-XX-96	6.0	152	2.28	58	1.0	25

Code: XX = S6 (316SS), AL (Aluminum)

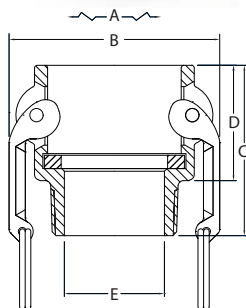

Male Camlock Adapter Coupler 733B/633B

Material: SA351 CF8M/SA479 T316 | Code: XX = S6 (316SS), AL (Aluminum)

Pressure: 250 psi (2.5" ID or less), 150 psi (3" - 6" ID) - Stainless Steel Only

Gasket Material: Buna-N (Standard) Options: EPDM, FKM & PTFE Encapsulated Rubber (ER)

Temperature: Buna-N 100°C (210°F), EPDM, FKM, PTFE (ER) 120°C (250°F)

Thread Size: Standard NPT Optional: Use Code ZZ & Specify (BSP, BSPT, DIN, JIS)

Part Number	Adapter Size		Thread Size		(A) O.D. Extended Cam Arms		(B) Outside Diameter		(C) Overall Length		(D) Exposed Length		(E) Inside Diameter	
	in	mm	in	mm	in	mm	in	mm	in	mm	in	mm	in	mm
(N)733B(633B)-XX-Y-08	.5	13	.5	13	4.51	115	2.11	54	2.10	53	1.25	32	.56	14
(N)733B(633B)-XX-Y-12	.75	20	.75	20	4.51	115	2.11	54	2.10	53	1.25	32	.78	20
(N)733B(633B)-XX-Y-16	1.0	25	1.0	25	5.10	130	2.44	62	2.50	64	1.56	40	.97	25
(N)733B(633B)-XX-Y-20	1.25	32	1.25	32	6.86	174	3.26	83	2.89	73	1.84	47	1.25	32
(N)733B(633B)-XX-Y-24	1.5	38	1.5	38	7.16	182	3.56	90	2.93	74	1.88	48	1.50	38
(N)733B(633B)-XX-Y-32	2.0	50	2.0	50	7.54	192	3.94	100	3.20	81	2.15	55	1.88	48
(N)733B(633B)-XX-Y-40	2.5	64	2.5	64	8.03	204	4.43	113	3.63	92	2.18	55	2.38	60
(N)733B(633B)-XX-Y-48	3.0	76	3.0	76	9.56	243	5.46	139	3.82	97	2.27	58	2.88	73
(N)733B(633B)-XX-Y-64	4.0	102	4.0	102	10.66	271	6.56	167	4.00	102	2.34	59	3.60	91
(N)733B(633B)-XX-Y-96	6.0	152	6.0	152	16.26	413	10.16	258	4.52	115	2.62	67	5.60	142

Note: When ordering 633C, pressures are less than shown above | Part Number Material Codes: XX = S6 (316SS)

Part Number Gasket Codes: Y = D (Nitrile), H (EPDM), I (FKM), PTFE Encapsulated Rubber Codes: JD (Nitrile), JH (EPDM), JI (FKM)



Female Camlock Adapter Coupler 733D/633D

Material: SA351 CF8M/SA479 T316 | Code: XX = S6 (316SS), AL (Aluminum)

Pressure: 250 psi (2.5" ID or less), 150 psi (3" - 6" ID) - Stainless Steel Only

Gasket Material: Buna-N (Standard) Options: EPDM, FKM & PTFE Encapsulated Rubber (ER)

Temperature: Buna-N 100°C (210°F), EPDM, FKM, PTFE (ER) 120°C (250°F)

Thread Size: Standard NPT Optional: Use Code ZZ & Specify (BSP, BSPT, DIN, JIS)

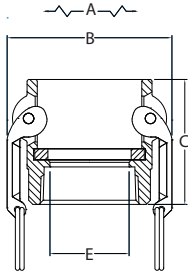

Part Number	Adapter Size		Thread Size		(A) O.D. Extended Cam Arms		(B) Outside Diameter		(C) Overall Length		(E) Inside Diameter	
	in	mm	in	mm	in	mm	in	mm	in	mm	in	mm
(N)733D(633D)-XX-Y-08	.5	13	.5	13	4.51	115	2.11	54	2.10	53	.67	17
(N)733D(633D)-XX-Y-12	.75	20	.75	20	4.51	115	2.11	54	2.10	53	.88	22
(N)733D(633D)-XX-Y-16	1.0	25	1.0	25	5.10	130	2.44	62	2.50	64	.97	25
(N)733D(633D)-XX-Y-20	1.25	32	1.25	32	6.86	174	3.26	83	2.70	69	1.25	32
(N)733D(633D)-XX-Y-24	1.5	38	1.5	38	7.16	182	3.56	90	2.80	71	1.50	38
(N)733D(633D)-XX-Y-32	2.0	50	2.0	50	7.54	192	3.94	100	3.10	79	1.88	48
(N)733D(633D)-XX-Y-40	2.5	64	2.5	64	8.03	204	4.43	113	3.40	86	2.38	60
(N)733D(633D)-XX-Y-48	3.0	76	3.0	76	9.56	243	5.46	139	3.50	89	2.88	73
(N)733D(633D)-XX-Y-64	4.0	102	4.0	102	10.66	271	6.56	167	3.90	99	3.60	91
(N)733D(633D)-XX-Y-96	6.0	152	6.0	152	16.26	413	10.16	258	4.40	112	5.50	140

Note: * Sizes for 733C-HD Only. When ordering 633C, pressures are less than shown above | Part Number Material Codes: XX = S6 (316SS)
Part Number Gasket Codes: Y = D (Nitrile), H (EPDM), I (FKM), PTFE Encapsulated Rubber Codes: JD (Nitrile), JH (EPDM), JI (FKM)



Butt Weld Camlock Adapter Coupler 733FBW/733FBW-HD/633FBW

Material: SA351 CF8M/SA479 T316 | Code: XX = S6 (316SS)

Pressure: 250 psi (2.5" ID or less), 150 psi (3" - 6" ID) - Stainless Steel Only

Gasket Material: Buna-N (Standard) Options: EPDM, FKM & PTFE Encapsulated Rubber (ER)

Temperature: Buna-N 100°C (210°F), EPDM, FKM, PTFE (ER) 120°C (250°F)

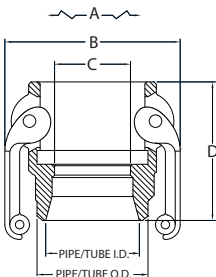

Part Number	Adapter Size		(A) O.D. Extended Cam Arms		(B) Outside Diameter		(C) Inside Diameter		(D) Overall Length	
	in	mm	in	mm	in	mm	in	mm	in	mm
(N)733FBW(-HD)(633FBW)-XX-Y-08	.5	13	4.21	107	1.82	46	.56	14	2.0	50
(N)733FBW(-HD)(633FBW)-XX-Y-12	.75	20	4.51	115	2.11	54	.78	20	2.0	50
(N)733FBW(-HD)(633FBW)-XX-Y-16	1.0	25	5.10	130	2.44	62	.97	25	2.51	64
(N)733FBW(-HD)(633FBW)-XX-Y-20	1.25	32	6.86	174	3.26	83	1.25	32	2.89	73
(N)733FBW(-HD)(633FBW)-XX-Y-24	1.5	38	7.16	182	3.56	90	1.54	39	2.81	71
(N)733FBW(-HD)(633FBW)-XX-Y-32	2.0	50	7.54	192	3.94	100	1.88	48	3.20	81
(N)733FBW(-HD)(633FBW)-XX-Y-40	2.5	64	8.03	204	4.43	113	2.38	61	3.63	92
(N)733FBW(-HD)(633FBW)-XX-Y-48	3.0	76	9.56	243	5.46	139	2.88	73	3.82	97
(N)733FBW(-HD)(633FBW)-XX-Y-64	4.0	102	10.66	271	6.56	167	3.5	89	4.00	102
(N)733FBW(-HD)(633FBW)-XX-Y-96	6.0	152	16.26	413	10.16	258	5.5	140	4.54	115

Note: * Sizes for 733C-HD Only. When ordering 633C, pressures are less than shown above | Part Number Material Codes: XX = S6 (316SS)
Part Number Gasket Codes: Y = D (Nitrile), H (EPDM), I (FKM), PTFE Encapsulated Rubber Codes: JD (Nitrile), JH (EPDM), JI (FKM)



Socket Weld Camlock Adapter Coupler 733DSW/733DSW-HD/633DSW

Material: SA351 CF8M/SA479 T316 | Code: XX = S6 (316SS)

Pressure: 250 psi (2.5" ID or less), 150 psi (3" - 6" ID) - Stainless Steel Only

Gasket Material: Buna-N (Standard) Options: EPDM, FKM & PTFE Encapsulated Rubber (ER)

Temperature: Buna-N 100°C (210°F), EPDM, FKM, PTFE (ER) 120°C (250°F)

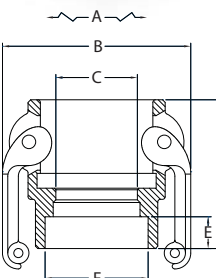

Part Number	Adapter Size		(A) O.D. Ext. Cam Arms		(B) Outside Diameter		(C) Inside Diameter		(D) Overall Length		(E) Socket Depth		(F) Socket Diameter Pipe		(F) Socket Diameter Tube	
	in	mm	in	mm	in	mm	in	mm	in	mm	in	mm	in	mm	in	mm
(N)733DSW(-HD)(633DSW)-XX-Y-08	.5	13	4.21	107	1.82	46	.56	14	2.00	50	.50	13	.88	22	.52	13
(N)733DSW(-HD)(633DSW)-XX-Y-12	.75	20	4.51	115	2.11	54	.88	22	2.06	52	.50	13	1.10	28	.77	20
(N)733DSW(-HD)(633DSW)-XX-Y-16	1.0	25	5.10	130	2.44	62	.97	24	2.50	64	.50	13	1.36	35	1.02	26
(N)733DSW(-HD)(633DSW)-XX-Y-20	1.25	32	6.86	174	3.26	83	1.25	32	2.70	69	.50	13	1.71	43	1.27	32
(N)733DSW(-HD)(633DSW)-XX-Y-24	1.5	38	7.16	182	3.56	90	1.50	38	2.81	71	.50	13	1.95	49	1.52	39
(N)733DSW(-HD)(633DSW)-XX-Y-32	2.0	50	7.54	192	3.94	100	1.88	48	3.10	79	.70	18	2.44	62	2.02	51
(N)733DSW(-HD)(633DSW)-XX-Y-40	2.5	64	8.03	204	4.43	113	2.38	60	3.40	86	.70	18	2.94	75	3.02	77
(N)733DSW(-HD)(633DSW)-XX-Y-48	3.0	76	9.56	243	5.46	139	2.88	73	3.50	89	.70	18	3.57	91	4.03	102
(N)733DSW(-HD)(633DSW)-XX-Y-64	4.0	102	10.66	271	6.56	167	3.60	91	3.90	99	.70	18	4.58	116	5.03	128
(N)733DSW(-HD)(633DSW)-XX-Y-96	6.0	152	16.26	413	10.16	258	5.50	140	4.54	115	.90	23	6.72	171	6.03	153

Note: * Sizes for 733C-HD Only. When ordering 633C, pressures are less than shown above | Part Number Material Codes: XX = S6 (316SS)
Part Number Gasket Codes: Y = D (Nitrile), H (EPDM), I (FKM), PTFE Encapsulated Rubber Codes: JD (Nitrile), JH (EPDM), JI (FKM)



Female Heavy Duty Camlock Adapter Coupler 733DSW-HD

Material: SA351 CF8M/SA479 T316 | Code: XX = S6 (316SS)

Pressure: 250 psi (2.5" ID or less), 150 psi (3" - 6" ID) - Stainless Steel Only

Gasket Material: Buna-N (Standard) Options: EPDM, FKM & PTFE Encapsulated Rubber (ER)

Temperature: Buna-N 100°C (210°F), EPDM, FKM, PTFE (ER) 120°C (250°F)

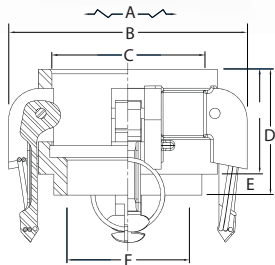

Part Number	Adapter Size		(A) O.D. Ext. Cam Arms		(B) Outside Diameter		(C) Inside Diameter		(D) Overall Length		(E) Socket Depth		(F) Socket Diameter Pipe Tube			
	in	mm	in	mm	in	mm	in	mm	in	mm	in	mm	in	mm	in	mm
(N)733DSW-HD-XX-Y-08	.5	13	4.21	107	1.82	46	.56	14	2.00	50	.50	13	.88	22	.52	13
(N)733DSW-HD-XX-Y-12	.75	20	4.51	115	2.11	54	.88	22	2.06	52	.50	13	1.10	28	.77	20
(N)733DSW-HD-XX-Y-16	1.0	25	5.10	130	2.44	62	.97	24	2.50	64	.50	13	1.36	35	1.02	26
(N)733DSW-HD-XX-Y-20	1.25	32	6.86	174	3.26	83	1.25	32	2.70	69	.50	13	1.71	43	1.27	32
(N)733DSW-HD-XX-Y-24	1.5	38	7.16	182	3.56	90	1.50	38	2.81	71	.50	13	1.95	49	1.52	39
(N)733DSW-HD-XX-Y-32	2.0	50	7.54	192	3.94	100	1.88	48	3.10	79	.70	18	2.44	62	2.02	51
(N)733DSW-HD-XX-Y-40	2.5	64	8.03	204	4.43	113	2.38	60	3.40	86	.70	18	2.94	75	3.02	77
(N)733DSW-HD-XX-Y-48	3.0	76	9.56	243	5.46	139	2.88	73	3.50	89	.70	18	3.57	91	4.03	102
(N)733DSW-HD-XX-Y-64	4.0	102	10.66	271	6.56	167	3.60	91	3.90	99	.70	18	4.58	116	5.03	128
(N)733DSW-HD-XX-Y-96	6.0	152	16.26	413	10.16	258	5.50	140	4.54	115	.90	23	6.72	171	6.03	153

Note: * Sizes for 733C-HD Only. When ordering 633C, pressures are less than shown above | Part Number Material Codes: XX = S6 (316SS)
Part Number Gasket Codes: Y = D (Nitrile), H (EPDM), I (FKM), PTFE Encapsulated Rubber Codes: JD (Nitrile), JH (EPDM), JI (FKM)



Camlock Dust Cap 733DC/633DC

Material: SA351 CF8M/SA479 T316 | Code: XX = S6 (316SS), AL (Aluminum)

Pressure: 150 psi (2.5" ID or less), 75 psi (3" - 6" ID) - Stainless Steel Only

Gasket Material: Buna-N (Standard) Options: EPDM, FKM & PTFE Encapsulated Rubber (ER)

Temperature: Buna-N 100°C (210°F), EPDM, FKM, PTFE (ER) 120°C (250°F)

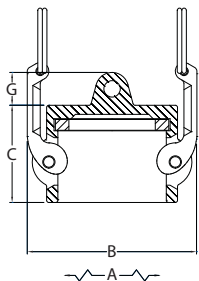

Part Number	Adapter Size		(A) O.D. Ext. Cam Arms		(B) Outside Diameter		(C) Overall Length		(G) Chain Lug Extension	
	in	mm	in	mm	in	mm	in	mm	in	mm
(N)733DC(633DC)-XX-Y-08	.5	13	4.21	107	1.82	46	1.30	33	.5	13
(N)733DC(633DC)-XX-Y-12	.75	20	4.51	115	2.11	54	1.35	34	.5	13
(N)733DC(633DC)-XX-Y-16	1.0	25	5.10	130	2.44	62	1.60	41	.62	16
(N)733DC(633DC)-XX-Y-20	1.25	32	6.86	174	3.26	83	1.89	48	.60	15
(N)733DC(633DC)-XX-Y-24	1.5	38	7.16	182	3.56	90	1.96	50	.86	22
(N)733DC(633DC)-XX-Y-32	2.0	50	7.54	192	3.94	100	2.25	57	.76	19
(N)733DC(633DC)-XX-Y-40	2.5	64	8.03	204	4.43	113	2.28	58	.90	23
(N)733DC(633DC)-XX-Y-48	3.0	76	9.56	243	5.46	139	2.27	58	1.03	26
(N)733DC(633DC)-XX-Y-64	4.0	102	10.66	271	6.56	167	2.34	59	.99	25
(N)733DC(633DC)-XX-Y-96	6.0	152	16.26	413	10.16	258	2.76	70	1.14	29

Note: * Sizes for 733C-HD Only. When ordering 633C, pressures are less than shown above | Part Number Material Codes: XX = S6 (316SS)
Part Number Gasket Codes: Y = D (Nitrile), H (EPDM), I (FKM), PTFE Encapsulated Rubber Codes: JD (Nitrile), JH (EPDM), JI (FKM)



Camlock Flanged Adapter Coupler 633-PFC 150# PN10

Material: SA351 CF8M/SA479 T316 | Code: XX = S6 (316SS)

Pressure: 150 psi (2.5" ID or less), 75 psi (3" - 6" ID) - Stainless Steel Only

Gasket Material: Buna-N (Standard) Options: EPDM, FKM & PTFE Encapsulated Rubber (ER)

Temperature: Buna-N, EPDM (250°F), FKM, PTFE (ER) (210°F)

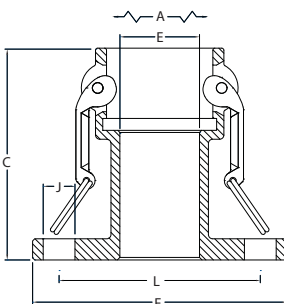

Part Number	Adapter/ Flange Size		(A) O.D. Ext. Cam Arms		(C) Overall Length		(E) Inside Diameter		(F) Outside Diameter		(J) Bolt Hole Diameter		(K) Number of Holes		(L) Bolt Circle Diameter	
	in	mm	in	mm	in	mm	in	mm	in	mm	in	mm	#	in	mm	
(N)633-PFE-XX-Y-16	1.0	1	5.04	128	3.48	88	.69	18	4.25	108	.63	16	4	3.13	80	
(N)633-PFE-XX-Y-24	1.5	2	7.16	182	5.25	133	1.15	34	5.0	127	.63	16	4	3.88	99	
(N)633-PFE-XX-Y-32	2.0	3	7.54	192	5.82	148	1.63	41	6.0	152	.75	19	4	4.75	121	
(N)633-PFE-XX-Y-40	2.5	4	8.03	204	5.09	129	2.38	60	7.0	178	.75	19	4	5.5	140	
(N)633-PFE-XX-Y-48	3.0	5	9.56	243	5.82	148	2.90	74	7.5	191	.75	19	4	6.0	152	
(N)633-PFE-XX-Y-64	4.0	6	10.66	271	5.39	137	3.60	91	9.0	229	.75	19	8	7.5	191	
(N)633-PFE-XX-Y-96	6.0	7	16.76	426	7.75	197	5.60	142	11.0	279	.88	22	8	9.5	241	

Note: * Sizes for 733C-HD Only. When ordering 633C, pressures are less than shown above | Part Number Material Codes: XX = S6 (316SS)
Part Number Gasket Codes: Y = D (Nitrile), H (EPDM), I (FKM), PTFE Encapsulated Rubber Codes: JD (Nitrile), JH (EPDM), JI (FKM)



Camlock Flanged Adapter 633-PFE 150# PN10

(Use prefix "N" only for ASME Code Applications)

Material: SA351 CF8M/SA479 T316 | Code: XX = S6 (316SS), AL (Aluminum)

Pressure: 150 psi (2.5" ID or less), 75 psi (3" - 6" ID) - Stainless Steel Only

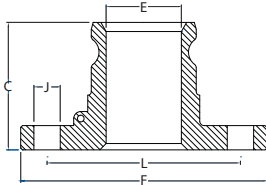

Part Number	Adapter/ Flange Size		(C) Overall Length		(E) Inside Diameter.		(F) Outside Diameter		(J) Bolt Hole Diameter		(K) Number of Holes	(L) Bolt Circle Diameter	
	in	mm	in	mm	in	mm	in	mm	in	mm	#	in	mm
(N)633-PFE-XX-16	1.0	25	2.32	59	.88	22	4.25	108	.63	16	4	3.13	80
(N)633-PFE-XX-24	1.5	38	3.56	90	1.34	34	5.0	127	.63	16	4	3.88	99
(N)633-PFE-XX-32	2.0	50	3.50	89	1.72	44	6.0	152	.75	19	4	4.75	121
(N)633-PFE-XX-40	2.5	64	3.63	92	2.14	54	7.0	178	.75	19	4	5.5	140
(N)633-PFE-XX-48	3.0	76	3.69	94	2.78	71	7.5	191	.75	19	4	6.0	152
(N)633-PFE-XX-64	4.0	102	4.0	102	3.78	96	9.0	229	.75	19	8	7.5	191
(N)633-PFE-XX-96	6.0	152	4.5	114	5.56	141	11.0	279	.88	22	8	9.5	241

Code: XX = S6 (316SS), AL (Aluminum)



Camlock 633-TTC Tank & Truck Adapter Coupler

Material: SA351 CF8M/SA479 T316 | Code: XX = S6 (316SS)

Pressure: 150 psi (2.5" ID or less), 75 psi (3" - 6" ID) - Stainless Steel Only

Gasket Material: Buna-N (Standard) Options: EPDM, FKM & PTFE Encapsulated Rubber (ER)

Temperature: Buna-N 100°C (210°F), EPDM, FKM, PTFE (ER) 120°C (250°F)

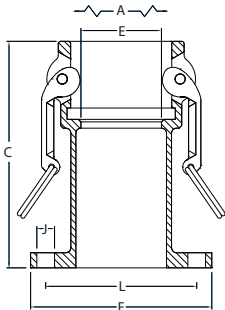

Part Number	Adapter/ Flange Size		(A) O.D. Ext. Cam Arms		(C) Overall Length		(E) Inside Diameter.		(F) Outside Diameter		(J) Bolt Hole Diameter		(K) Number of Holes	(L) Bolt Circle Diameter	
	in	mm	in	mm	in	mm	in	mm	in	mm	in	mm	#	in	mm
(N)633-TTC-XX-Y-32	2.0	50	7.54	192	5.63	143	2.0	51	4.5	114	.44	11	6	3.75	95
(N)633-TTC-XX-Y-48	3.0	76	9.56	243	5.66	144	2.9	74	5.63	143	.44	11	8	4.88	124
(N)633-TTC-XX-Y-64	4.0	102	10.66	271	5.68	144	3.6	91	6.63	158	.44	11	8	5.88	149
(N)633-TTC-XX-Y-96	6.0	152	16.26	413	7.25	184	5.6	142	8.88	226	.44	11	12	8.13	207

Note: * Sizes for 733C-HD Only. When ordering 633C, pressures are less than shown above | Part Number Material Codes: XX = S6 (316SS)
Part Number Gasket Codes: Y = D (Nitrile), H (EPDM), I (FKM), PTFE Encapsulated Rubber Codes: JD (Nitrile), JH (EPDM), JI (FKM)



Camlock 633-TTE Tank & Truck Adapter

(Use prefix "N" only for ASME Code Applications)

Material: SA351 CF8M/SA479 T316 | Code: XX = S6 (316SS), AL (Aluminum)

Pressure: 150 psi (2.5" ID or less), 75 psi (3" - 6" ID) - Stainless Steel Only

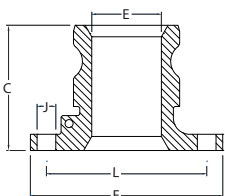

Part Number	Adapter/ Flange Size		(C) Overall Length		(E) Inside Diameter.		(F) Outside Diameter		(J) Bolt Hole Diameter		(K) Number of Holes	(L) Bolt Circle Diameter	
	in	mm	in	mm	in	mm	in	mm	in	mm	#	in	mm
(N)633-TTE-XX-32	2.0	50	2.93	74	1.63	41	4.5	114	.44	11	6	3.75	95
(N)633-TTE-XX-48	3.0	76	3.38	86	2.8	71	5.63	143	.44	11	8	4.88	124
(N)633-TTE-XX-64	4.0	102	3.35	85	3.78	96	6.63	168	.44	11	8	5.88	149
(N)633-TTE-XX-96	6.0	152	4.88	124	5.84	148	8.88	226	.44	11	12	8.13	207

Code: XX = S6 (316SS), AL (Aluminum)

Camlock Elbow Quick Couplings



Camlock 633-90CC 90° X 90° Coupler

Material: SA351 CF8M/SA479 T316 | **Code:** XX = S6 (316SS), AL = Aluminum

Pressure: 75 psi (2" ID), 50 psi (3" - 6" ID)

Gasket Material: Buna-N (Standard) Options: EPDM, FKM & PTFE Encapsulated Rubber (ER)

Temperature: Buna-N 100°C (210°F), EPDM, FKM, PTFE (ER) 120°C (250°F)

Part Number	Adapter / Flange Size	
	in	mm
(N)633-90CC-XX-Y-32	2.0	50
(N)633-90CC-XX-Y-48	3.0	76
(N)633-90CC-XX-Y-64	4.0	102
(N)633-90CC-XX-Y-96	6.0	152

Part Number Material Codes: XX = S6 (316SS) **Part Number Gasket Codes:** Y = D (Nitrile), H (EPDM), I (FKM), PTFE Encapsulated Rubber Codes: JD (Nitrile), JH (EPDM), JI (FKM)



Camlock 633-90EC 90° Coupler X Male Adapter

Material: SA351 CF8M/SA479 T316 | **Code:** XX = S6 (316SS), AL = Aluminum

Pressure: 75 psi (2" ID), 50 psi (3" - 6" ID)

Gasket Material: Buna-N (Standard) Options: EPDM, FKM & PTFE Encapsulated Rubber (ER)

Temperature: Buna-N 100°C (210°F), EPDM, FKM, PTFE (ER) 120°C (250°F)

Part Number	Adapter / Flange Size	
	in	mm
(N)633-90EC-XX-Y-32	2.0	50
(N)633-90EC-XX-Y-48	3.0	76
(N)633-90EC-XX-Y-64	4.0	102
(N)633-90EC-XX-Y-96	6.0	152

Part Number Material Codes: XX = S6 (316SS) **Part Number Gasket Codes:** Y = D (Nitrile), H (EPDM), I (FKM), PTFE Encapsulated Rubber Codes: JD (Nitrile), JH (EPDM), JI (FKM)



Camlock 633-90FPC 90° Coupler X Female NPT

Material: SA351 CF8M/SA479 T316 | **Code:** XX = S6 (316SS), AL = Aluminum

Pressure: 75 psi (2" ID), 50 psi (3" - 6" ID)

Gasket Material: Buna-N (Standard) Options: EPDM, FKM & PTFE Encapsulated Rubber (ER)

Temperature: Buna-N 100°C (210°F), EPDM, FKM, PTFE (ER) 120°C (250°F)

Part Number	Adapter/Flange Size	
	in	mm
(N)633-90FPC-XX-Y-32	2.0	50
(N)633-90FPC-XX-Y-48	3.0	76
(N)633-90FPC-XX-Y-64	4.0	102
(N)633-90FPC-XX-Y-96	6.0	152

Part Number Material Codes: XX = S6 (316SS) **Part Number Gasket Codes:** Y = D (Nitrile), H (EPDM), I (FKM), PTFE Encapsulated Rubber Codes: JD (Nitrile), JH (EPDM), JI (FKM)

Bottom Loading Accessories



Model BLS-1 Single Outboard Swing Joint

Thorburn's long radius single swing joint is specifically designed for use on hose loaders. It allows for 360° rotation on the horizontal plane. Cast aluminum construction makes it lightweight, yet rugged and durable. Long radius design provides for low pressure drop. The BLS-1 has the same seals used in our fabricated swivel joints. The seals are available in Viton, Buna N and PTFE. The BLS-1 is supplied with 4" tank truck flange for use with Thorburn's TJ942-API coupler.



Part Number	
BLS-1D	BUNA N Seals
BLS-1I	Viton Seals
BLS-1J	PTFE Seals



Model BLS-2 Double Outboard Swing Joint

The BLS-2 double swing joint is used to make outboard connections on "A" frame styles of bottom loaders. It can rotate 360° in both the horizontal and vertical planes to facilitate alignment during coupling. Cast aluminum construction is available in 2" through 6" sizes. Quad-Ring seals available in Viton and Buna N.

Part Number	Size Code	Size (in)	Size (DIN)	Seal	Seal Code
BLS-2	32	2	50	BUNA N	D
	48	3	80	Viton	I
	64	4	100	PTFE	J
	96	6	150		



Model TJ942-API Coupler

Thorburn's TJ942 is the standard for the industry. A true work horse with a solid reputation built on years of service. It is an API style dry-break coupler built to conform with API RP- 1004. It is available in a 4" size only. Thorburn's TJ942 is designed with an interlock so that the coupler cannot be opened unless it is properly connected to an API style adapter. Once coupled, it cannot be uncoupled while the valve is open. Constructed of aluminum, this durable coupler has a 4" tank truck flanged inlet.

Thorburn's API coupler has a special seal design that allows the poppet, nose and side seals to be replaced without disassembling the coupler or removing it from the loading arm. Standard seals are Viton Orings. Other elastomers available.

SJ Series - Low Pressure Swivel Joints

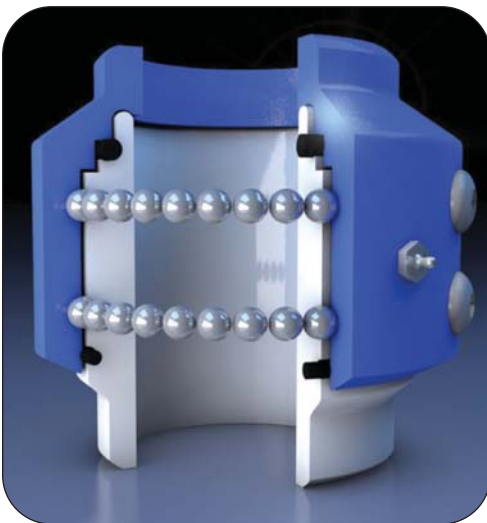

Thorburn's SJ Series Ball Bearing Live Swivel

Thorburn's SJ Series Swivel Joints make it possible to use rigid metal piping for loading and unloading caustic or hazardous liquids, petroleum, dry products such as grains, cement, and other material, under pressure or vacuum, without the difficulty of manhandling heavy, cumbersome hoses.

In circumstances where the use of a hose is necessary, Thorburn swivel joints, mounted at the end of the hose, will eliminate kinking and twisting. In other cases, metal frameworks fitted with swivel joints, to which hosing is attached, will guide the hose more easily, and keep uncontrolled hose from kinking or from denting or scratching tanks, trucks and other equipment.

Thorburn swivel joints have a broad range of uses in the petroleum, machine tool, chemical, refining, mining, distilling, brewing, and paint industries, as well as farm irrigation and fertilizing and hundreds of others.

Thorburn swivel joints are standard in combinations of five metals and five seal materials so that you can order, from stock, the ones that are most suitable for the products you handle. Two types of body construction (Cast and Fabricated) cover pressures, temperatures, corrosion resistance, weights and load-bearing capacities well within the requirements of most products handled. From the pressure/temperature graphs shown below, you can easily determine which metals and seals you need. Thorburn swivel joints are available in the following materials with pressure ratings as shown:

Maximum Rated Pressure 2 inch (DIN50) SJ Swivel Joint

Cast Bronze	100 psi	Buna-N seals are standard with all of the above swivel joints, but each is available with seals made of Neoprene, Teflon, EPT or Viton-A, depending on the pressures and temperatures of your operation.
Cast Aluminum	100 psi	
Cast Stainless Steel	500 psi	
Cast Ductile Iron	300 psi	
Fabricated Steel	500 psi	
Fabricated Stainless Steel	500 psi	

Contact Thorburn Flex with application details for specific Temperature / Pressure suitability



Thorburn's 316SS single fabricated "SJ" Series live swivel joint with 90° elbow flanges

1 Plane of Rotation

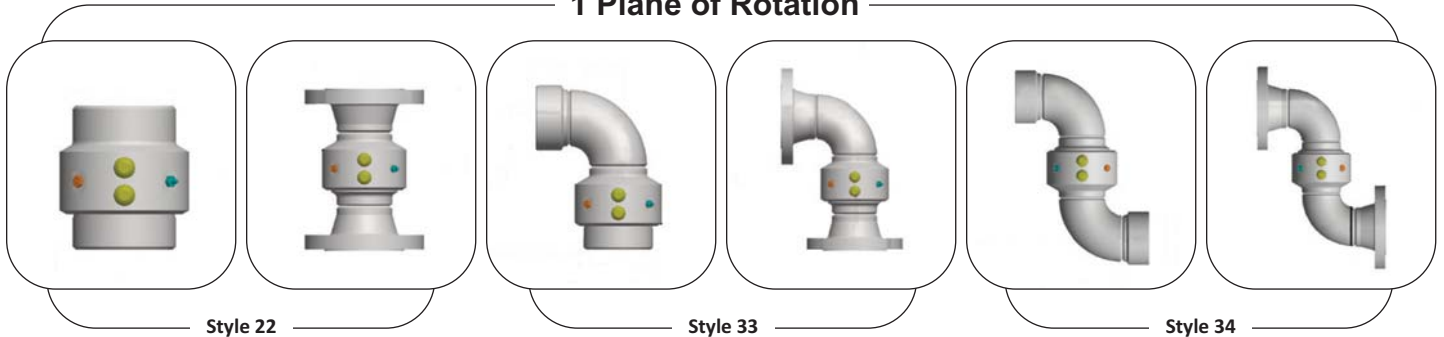

2 Planes of Rotation

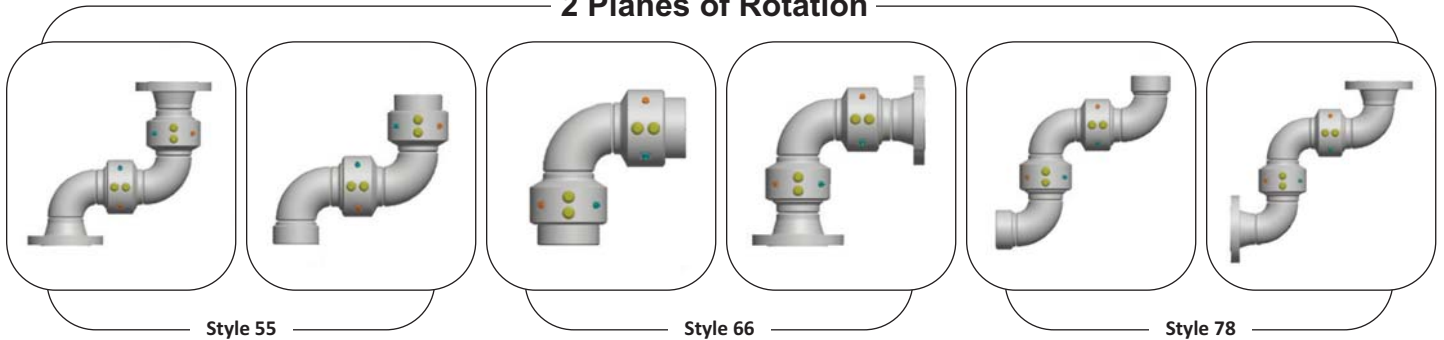

3 Planes of Rotation

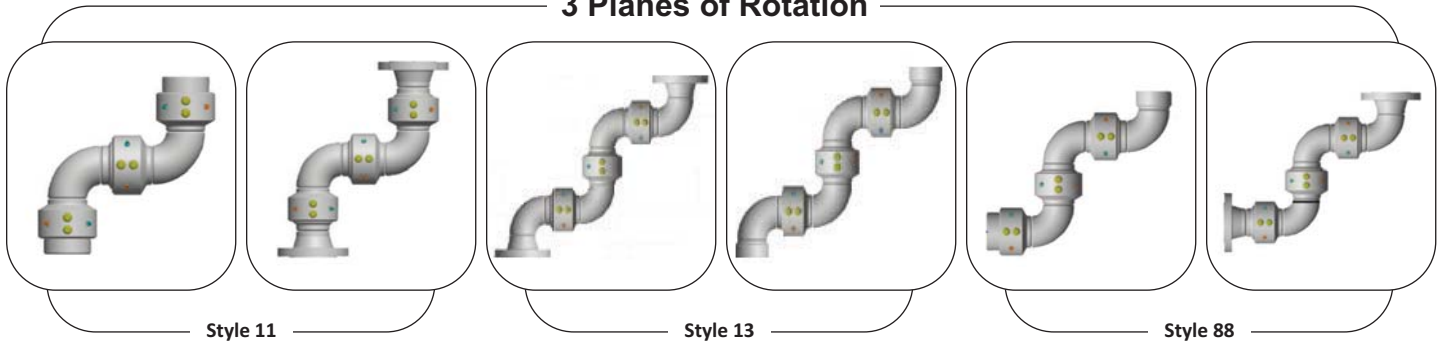

How to Order Thorburn Series SJ Swivel Joints

Model	Size	Material	Style	1st End	2nd End	Seal
SJ	48	2	11	F1	T1	B
	Hose size in 1/16 of an inch Examples: 01 = 1/16 02 = 1/8 04 = 1/4 06 = 3/8 08 = 1/2 12 = 3/4 48 = 3... etc.	1 = Bronze 2 = Aluminum 3 = Fab. Steel 4 = Cast Stainless Steel 5 = Fab. SS304 6 = Fab. SS316	11 55 13 66 22 78 33 88 34 SP**	F1 = Flanged ANSI Class 150 F2 = Flanged ANSI Class 300 T1 = Female NPT B1 = Butt Weld SW = Socket Weld XX = Special (Specify)	B = Buna N V = Viton N = Neoprene E = EPDM T = PTFE X = Other (Specify)	

Some materials may not be available for certain sizes. Contact Thorburn.
* For materials other than listed, insert Code X and specify.
** SP = Special.

Types Of Corrosion



Thorburn's flexible metal hoses are suitable for the transport of critical fluids if a sufficient resistance is ensured against all corrosive media that may occur during the lifetime of the hose. The flexibility of the hose's corrugated elements require their wall thickness to be considerably thinner than that of all other parts of the piping system. Special attention must be paid to all possible kinds of corrosion, especially pitting corrosion, intergranular corrosion, crevice corrosion and stress corrosion cracking. This leads to the fact that the corrugated flexible element that is exposed to the corrosive fluid has to be chosen from a material with even higher corrosion resistance than those of the piping system parts it is connected to.

According to EN ISO 8044, corrosion is the "physicochemical interaction between a metal and its environment that results in changes in the properties of the metal, and which may lead to significant impairment of the function of the metal, the environment, or the technical system, of which these form a part. This interaction is often of an electrochemical nature". Different types of corrosion may occur, depending on the material and on the corrosion conditions.



Uniform Corrosion

A general corrosion proceeding at almost the same rate over the whole surface. This type of corrosion includes rust which commonly is found on unalloyed steel (e. g. caused by oxidation in the presence of water). Stainless steels can only be affected by uniform corrosion under extremely unfavorable conditions, e.g. caused by liquids, such as acids and salt solutions. The loss in weight is specified in g/m²h or as the reduction in the wall thickness in mm/year.



Pitting Corrosion

A locally limited corrosion attack that may occur under certain conditions, called pitting corrosion on account of its appearance. It is caused by the effects of chlorine, bromine and iodine ions, especially when they are present in hydrous solutions. This selective type of corrosion cannot be calculated, unlike surface corrosion, and can therefore only be kept under control by choosing an adequate resistant material. The resistance of stainless steels to pitting corrosion increases in line with the molybdenum content in the chemical composition of the material.



Crevice Corrosion

This type of corrosion is caused by the lack of oxygen in crevices which results in a localized attack on a metal surface at, or immediately adjacent to, the gap or crevice between two joining surfaces. The gap or crevice can be formed between two metals or a metal and non-metallic material. Examples of crevices are gaps and contact areas between parts, under gaskets or seals, inside cracks and seams and spaces filled with deposits.

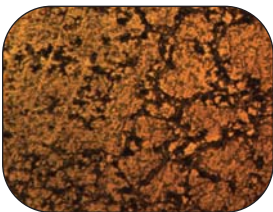

Intergranular Corrosion

Intergranular corrosion is a local, selective type of corrosion which primarily affects the grain boundaries. It is caused by deposits in the material structure, which lead to a reduction in the corrosion resistance in the regions close to the grain boundaries. In stainless steels this type of corrosion can advance up to the point where the grain composition is dissolved. These deposit processes are dependent on temperature (critical temperature range is between 550°C and 650°C) and time in CrNi alloys. The onset of the deposit processes differs according to the type of steel. Intergranular corrosion can be avoided by using stainless steels with low carbon content ($\leq 0,03\%$ C) or containing elements, such as titanium or niobium. Thin wall flexible elements made of materials such as 1.4541(SA 240 Type 321) or low-carbon qualities like 1.4404 (SA 240 Type 316L) can protect against intergranular corrosion. The resistance of materials to intergranular corrosion can be verified by a standardized test (Monypenny - Strauss test according to ISO 3651-2).

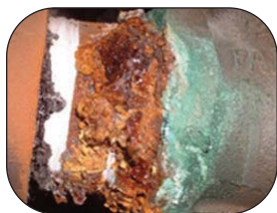

Dezincing

A type of corrosion which occurs primarily in copper-zinc alloys with more than 20% zinc. During the corrosion process the copper is separated from the brass and the zinc either remains in solution or is separated in the form of basic salts above the point of corrosion. The dezincing can be either of the surface type or locally restricted, and can also be found deeper inside. Conditions which encourage this type of corrosion include thick coatings from corrosion products, lime deposits from the water or other deposits of foreign bodies on the metal surface. Water with high chloride content at elevated temperature in conjunction with low flow velocities further the occurrence of dezincing.



Galvanic Corrosion

This type corrosion is an electrochemical process in which one metal corrodes preferentially when it is in electrical contact with another, in the presence of an electrolyte. A similar galvanic reaction is exploited in primary cells to generate a useful electrical voltage to power portable devices. Materials which can be encountered in both the active and passive state must also be taken into account. A CrNi alloy, for example, can be activated by mechanical damage to the surface, by deposits (diffusion of oxygen made more difficult) or by corrosion products on the surface of the material. This may result in a potential difference between the active and passive surfaces of the metal, and in material erosion (corrosion) if an electrolyte is present.



Stress corrosion cracking (SCC)

This type of corrosion is observed most frequently in austenitic materials, subjected to tensile stresses and exposed to a corrosive agent. The most common corrosive agents are alkaline solutions and those containing chlorides. The form of the cracks may be either transgranular or intergranular. Whereas the transgranular form only occurs at temperatures higher than 50°C (especially in solutions containing chloride), the intergranular form can be observed already at room temperature in austenitic materials in neutral solutions containing chloride. At temperatures above 100°C, SCC can already be caused by very small concentrations of chloride or lye – the latter always leads to the transgranular form. Stress corrosion cracking takes the same forms in non-ferrous metals as in austenitic materials. Damage caused by intergranular stress corrosion cracking can occur in nickel and nickel alloys in highly concentrated alkalis at temperatures above 400°C, and in solutions or water vapour containing hydrogen sulphide at temperatures above 250°C. A careful choice of materials based on a detailed knowledge of the existing operating conditions is necessary to prevent from this type of corrosion damage.

Bronze®

Alloy consisting of primarily copper (Cu) and around 12% tin (Sn) alloy

Monel® 400. UNS N04400 / EN 2.4360

A high nickel-copper alloy which offers superior strength and corrosion resistance with a wide range of media including seawater and chlorine.

Inconel® 625. UNS N06625 / EN 2.4856

A nickel-chromium-molybdenum super alloy with an addition of niobium that acts with the molybdenum to stiffen the alloy matrix and provides ultra-high strength without the need for heat treatment. This material provides superior resistance to pitting and crevice corrosion. Thorburn's Inconel 625 UNS NO6625 / EN 2.4856 is compliant with NACE MR0175-2009/ISO 15156-2009

Hastelloy® C-276. UNS N10276 / EN 2.4819

A nickel-chromium-molybdenum super alloy with addition of tungsten designed to have excellent corrosion resistance for severe environments Especially resistant to pitting and crevice corrosion. Resistant to the formation of grain boundary precipitants in the heat affected zone making it suitable for most chemical process applications in an as-welded condition.

Corrosion Resistance Tables

Table Key

Meanings of abbreviations

- adp:** acid dew point
- bp:** boiling point
- cs:** cold-saturated (@ room temp)
- dr:** dry condition
- hy:** hydrous solution
- me:** melted
- mo:** moist condition
- sa:** saturated (@ boiling point)

Assessment	Corrosion Behavior	Suitability
A	Resistant	Suitable
B	Uniform corrosion with reduction in thickness of up to 1 mm/year	Restricted suitability
C	Risk of pitting corrosion	
D	Risk of stress corrosion cracking	
E	Hardly resistant, uniform corrosion with reduction in thickness of more than 1 mm/year up to 10 mm/year	Not recommended
F	Not resistant (different forms of corrosion)	Unsuitable

Medium	Materials																
	Designation Chemical Formula	Concentration		Non/Low Alloy Steels	Stainless Steels				Nickel Based Alloys				Copper Based Alloys		Pure Metals		
		%	°C		409, 410L, 430	SS304, SS321	SS316, SS316L	Incoloy 825 2.4858	Inconel 600 2.4816	Inconel 625 2.4856	Hastelloy-C 2.4610 C276 2.4819	Monel 2.4360	Alloy CuNi 70/30	Bronze	Titanium	Tantalum	Aluminum
Acetanilide (Antifebrine) C ₈ H ₉ NO																	
Acetic acid CH ₃ COOH or C ₂ H ₄ O ₂	5 20 50 80 96 98	bp bp bp bp bp	F F F F F F	A A A A A A	A A A A A A	A A A A A A	A A A A A A	B A A A A A	A A A A A A	B B B B B B			A A A A A A	A A A A A A	A A A A A A		
Acetic acid vapour	33 100 100	20 -50 -bp	F F F	B F F	A A A	A A A	A A A	A A A	A A A	A A A	F F F		A A A	A A A	B F F		
Acetic aldehyde CH ₃ -CHO	100	bp	B	B	A	A	A	A	A	A	A	A	A	A	A	A	A
Acetic anhydride (CH ₃ -CO) ₂ O	all 100 100	20 60 bp	B F F	A A A	A A A	A A A	A A A	B F F	A A A	A A A	B B B	A A A	A A A	A A A	A A A	A A B	
Acetic anilide (Antifebrine)		<114	A	A	A	A	A	A	A	A	A	A	A	A	A	A	A
Acetone CH ₃ COCH ₃	100	bp	B	A	A	A	A	A	A	A	A	A	A	A	A	A	A
Acetyl chloride CH ₃ COCl		20	B	B	B	B	B	B	A	A	B	B	B	A	A	B	
Acetylene HC=CH	dr dr	200	A B	A A	A A	A A	A A	A A	A A	A A	A A	F F	F F	A A	A A	A B	
Acetylene dichloride C ₂ H ₂ Cl ₂	hy dr	5 100	20 20	A C	C	C	C	A	A	A	A					B A	
Acetylen tetrachloride CHCl ₂ -CHCl ₂	100 100	20 bp bp	A A B	A A A	A A A				A					A B	A F F		
Adipic acid HOOC(CH ₂) ₄ COOH	all	200	A	A	A	A	A	A	A	A	A			A	A	A	
Alcohol see ethyl or methyl alcohol																	

Medium	Materials																
	Designation Chemical Formula	Concentration		Non/Low Alloy Steels	Stainless Steels				Nickel Based Alloys				Copper Based Alloys		Pure Metals		
		%	°C		409, 410L, 430	SS304, SS321	SS316, SS316L	Incoloy 825 2.4858	Inconel 600 2.4816	Inconel 625 2.4856	Hastelloy-C 2.4610 C276 2.4819	Monel 2.4360	Alloy CuNi 70/30	Bronze	Titanium	Tantalum	Aluminum
Allyl alcohol CH ₂ CHCH ₂ OH	100	bp			A	A	A	A	A	A							
Allyl chloride CH ₂ =CHCH ₂ Cl	100	25			A	A	A	A	A		A						
Alum KAl(SO ₄) ₂	100 10 10	20 20 sa	hy hy	B B B	B A B	A A A	A A A	A A B	A A B	A A B	B B B	B B B	A A A	A A A	A A A	B B	
Aluminium Al	me	750		B	B	B	B						B		B		
Aluminium acetate (CH ₃ -COO) ₂ Al(OH)	hy sa	3 20		F F	A A	A A	A A			A B				A A	A B		
Aluminium chloride AlCl ₃	hy	5	20	F	F	F	C	B	B	A	A	B	F	B	A	A	
Aluminium fluoride AlF ₃	hy	10	25	F	F	F	F					B	B		A	F	
Aluminium formate Al(HCOO) ₃				B	A	A	A	A	A	A	A			A	A	A	
Aluminium hydroxide Al(OH) ₃	hy	10	20	B	F	A	A	A	A	A	A	F	A	A	A	F	
Aluminium nitrate Al(NO ₃) ₃				A	A	A	A	A	A	A	A			A	A	B	
Aluminium oxide Al ₂ O ₃		20		B	B	A	A	A	A	A	F	A	A		A	F	
Aluminium potassium sulphate see alum																	
Aluminium sulphate Al ₂ (SO ₄) ₃	hy	10 15	<bp 50	F F	F F	F F	A B	A	B	B	A	B	B	F	F	F	
Ammonia NH ₃	dr hy hy	10 2 20	20 20 40	A A A	A A A	A A A	A A A	A A A	A A A	A A A	B A B	A A F	D D	A A A	A A A	A B	

Medium				Materials																
Designation Chemical Formula	Concentration %	Temperature °C	Non/Low Alloy Steels	Stainless Steels			Nickel Based Alloys				Copper Based Alloys		Pure Metals							
				409, 410L, 430	SS304, SS321	SS316, SS316L	Incoloy 825 2.4858	Inconel 600 2.4816	Inconel 625 2.4856	Hastelloy-C 2.4610 C276 2.4819	Monel 2.4360	Alloy CuNi 70/30	Bronze	Titanium	Tantalum	Aluminium				
				F	C	C	A	A	A	A	A	A	A	A	B	B	D	A	A	A
Ammonia bromide NH ₄ Br	hy	10	25	F	C	C	C	A	Inconel 600 2.4816	A	B								A	B
Ammonium acetate CH ₃ -COONH ₄				B	A	A	A												A	A
Ammonium alum NH ₄ Al(SO ₄) ₂	hy	cs	20			A	A											F	A	
Ammonium bicarbonate (NH ₄)HCO ₃	hy			A	A	A	A	B	F			F	F					A	A	
Ammonium bifluoride NH ₄ HF ₂	hy	10	25	F	F	F	F											F	A	
Ammonium bromide see ammonia bromide	hy	100	20	F	F	A	A											F	A	
Ammonium carbonate NH ₄ CO ₃	hy	1	20	A	A	A	A	A	A	A	A	B	A	A				A	A	A
Ammonium chloride NH ₄ Cl	hy	1	20	B	C	C	C	C	A	A	A	A	A	B	B	D	A	A	B	B
Ammonium fluoride NH ₄ F	hy	10	25	B	C	C	C	C	A	A	A	A	A	B	B	D	A	A	B	B
Ammonium fluosilicate (NH ₄) ₂ SiF ₆	hy	20	40	F		B	A	A	A	A	A	A	A							
Ammonium formate HCOONH ₄	hy	10	20	B	A	A	A	A	A	A	A	A	A					A	A	A
Ammonium hydroxide NH ₄ OH	hy	10	70															A	A	A
Ammonium nitrate NH ₄ NO ₃	hy	5	20	F	A	A	A	A	B	A	A	A	F	F	F	F		A	A	A
Ammonium oxalate COONH ₄	hy	10	20	B	F	B	A	A	B	A	A	B	B	B				A	A	A
Ammonium perchlorate NH ₄ ClO ₄	hy	10	20	C	C	C					B							A		
Ammonium persulphate (NH ₄) ₂ S ₂ O ₈	hy	5	20	F	A	A	A	A	B	A	A	A	F	F	F	F		A	A	F
Ammonium phosphate NH ₄ H ₂ P ₂ O ₇	hy	5	25	A	B	B	A	A	B	A	A	A	B	B				A	A	B
Ammonium rhodanide NH ₄ CNS			70		A	A	A											A		A
Ammonium sulphate (NH ₄) ₂ SO ₄	hy	1	20	A	A	A	A	A	B	A	A	B	F	F	B			A	A	C
Ammonium sulphite (NH ₄) ₂ SO ₃	cs	10	20	B	A	A	F	F				F	F	F				A	A	
Ammonium sulphocyanate see ammonium rhodanide	sa	100	bp																	
Amyl acetate CH ₃ -COOC ₅ H ₁₁	all	100	20	B		B	B	B	B	B	B	B	A	A				B	B	A
Amyl alcohol C ₅ H ₁₁ OH	100	20	bp	A	A	A	A	A	A	A	A	A	A	A	A			A		B
Amyl chloride CH ₃ (CH ₂) ₄ CH ₂ Cl	100	bp	B		C	C	A	B	A	A	A	B	A					A	A	F
Amyl thiol	100	160			A	A					A									
Aniline C ₆ H ₅ NH ₂	100	100	180		A	B	A	B	A	A	A	F	F	F				A	A	F
Aniline chloride see aniline hydrochloride																				
Aniline hydrochloride C ₆ H ₅ NH ₂ ·HCl	hy	5	20	C	C	C					A		F					A	A	F
Aniline sulphite	hy	10	20					B			A							A	A	
Antifreeze Glysantine			20		A	A	A	A	A	A	A	A						A	A	A

Medium				Materials																
Designation Chemical Formula	Concentration %	Temperature °C	Non/Low Alloy Steels	Stainless Steels			Nickel Based Alloys				Copper Based Alloys		Pure Metals							
				409, 410L, 430	SS304, SS321	SS316, SS316L	Incoloy 825 2.4858	Inconel 600 2.4816	Inconel 625 2.4856	Hastelloy-C 2.4610 C276 2.4819	Monel 2.4360	Alloy CuNi 70/30	Bronze	Titanium	Tantalum	Aluminium				
				F	C	C	A	A	A	A	A	A	A	A	B	B	D	A	A	A
Antimony Sb	me	100	650	F																F
Antimony trichloride SbCl ₃	dr	20	100	A	F	F	F	F												F
Aqua regia 3HCl+HNO ₃		20		F	F	F	F	F			F		F					F	F	A
Arsenic As		65	110			A	A	B												
Arsenic acid H ₃ AsO ₄	hy	20	110	F	F	F	F	F			F							F		F
Asphalt		20		A	A	A	A	A										A	A	
Azobenzene C ₆ H ₅ -N=N-C ₆ H ₅		20		A	A	A	A	A	A	A	A	A	A	A	A			A	A	A
Baking powder	mo			B	A	A	A	A	A	A	A	A	A	A						A
Barium carbonate BaCO ₃		20	F	A	A	A	A	A			A	A	A	A	A	A	A	A	A	B
Barium chloride BaCl ₂	hy	5	20	C	C	C	C	B	B	B	A	A	A	B	F			A	A	F
Barium hydroxide Ba(OH) ₂	solid	100	20	A	A	A	A	A	A	A	B	B	A	A	B	A	B	A	A	F
	hy	100	20	A	A	A	A	A	A	A	A	B	B	A	A	B	A	A	A	F
	hy	100	815	A	A	A	A	A	A	A	A	B						A	A	F
	cs	20	bp	A	A	A	A	A	A	A	A	B						A	A	F
	sa	50	100	A	A	A	A	A	A	A	A	B						A	A	F
Barium nitrate Ba(NO ₃) ₂	hy	all	bp	A	A	A	A	A	B	A								F	F	
Barium sulphate BaSO ₄		25		A	A	A	A	A	A		A							A	A	A
Barium sulphide BaS		25		A	A	A												F	F	
Basic aluminium acetate see aluminium acetate																				
Beer		100	20	F	A	A	A	A	A	A	A	A	A	A	A	A	A	A	A	A
Benzaldehyde C ₆ H ₅ -CHO	dr	bp		A	A	A												B		A
Benzene		100	20	A	A	A	A	A	A	A	B	B	B	A	B	A	B	A	A	B
Benzenesulfonic acid C ₆ H ₅ -SO ₃ H	hy	5	40	F	A	A	A													
	hy	5	60	F	F	F	B	B												
Benzine		100	25	A	A	A	A	A	A	A	A	A	A	A	A	A	A	A	A	B
Benzoic acid C ₆ H ₅ COOH	hy	all	20	B	F	A	A	A	A	A	A	A	A	A	A	A	A	A	A	F
Benzyl alcohol C ₆ H ₅ -CH ₂ OH		all	20	B	B	A	A	A	A	A	A	A	A	A	A	A	A	A	A	
Biphenyl C ₆ H ₅ -C ₆ H ₅		100	20	A	A	D	D	A	A	A	A	A	A	A	A	A	A	A	A	A
		100	400	A	A	D	D	A	A	A	A	A	A	A	A	A	A	A	A	A
Blood		20	F	A	A	A	A	A	A	A	A	A	A	A	A	A	A	A	A	
Boiled acid		20	B	A	A	A	A	A	A	A	A	A	A	A	A	A	A	A	A	A
Borax Na ₂ B ₄ O ₇	hy	cs		B	A	A	A	A										A	A	A
	hy	sa		A	A	A	A											A	A	B
Boric acid H ₃ BO ₃	hy	50	100	F	A	A	A	A	B	A	A	A	A	A	A	A	B	A	A	B
	hy	50	150	F	B	A	A	A	B	A	A	A	A	A	A	A	B	A	A	B
	hy	70	150	F	B	B	B	B	A	B	A	A	A	A	A	A	B	A	A	B
Boron B		20	900	A	A	A	A													

Medium				Materials												
Designation Chemical Formula	Concentration		Temperature	Stainless Steels			Nickel Based Alloys				Copper Based Alloys		Pure Metals			
	%	°C		Non/Low Alloy Steels			Incoloy 825 2.4858	Inconel 600 2.4816	Inconel 625 2.4856	Hastelloy-C 2.4610 C276 2.4819	Monel 2.4360	Alloy CuNi 70/30	Bronze	Titanium	Tantalum	Aluminum
			409, 410L, 430	SS304, SS321	SS316, SS316L											
Diammonium phosphate <i>see ammonium phosphate</i>																
Dibromomethane CH ₂ Br-CH ₂ Br				B		A	A									F
Dichlorofluoromethane CF ₂ Cl ₂	dr dr mo		bp 20 20		A	A	A	A	A	A	A				A	A
Dichloroethane CH ₂ Cl-CH ₂ Cl	dr mo	100	20	A	C	C	C	B	A			A		A	A	A
Dichloroethylene <i>see acetylene dichloride</i>		100	20	A	C	C	C									
Diethyl ether (C ₂ H ₅) ₂ O				A	A	A	A	A	A	B	A	A	A	A	A	A
Ethane CH ₃ -CH ₃			20	A	A	A	A	A	A	A	A	A	A	A	A	A
Ether <i>see diethyl ether</i>																
Ethereal oils			20	B	A	A	A	A	A	B	A	A	A	A	A	A
Ethyl alcohol C ₂ H ₅ OH	all all	20	bp	A	A	A	A	A	A	A	A	A	A	A	A	A
Ethylbenzene C ₆ H ₅ -C ₂ H ₅				B	A	A	A	A	A	A	A	A	A	A	A	A
Ethyl chloride C ₂ H ₅ Cl				A	D	D	D	A	A	A	B	A		A	B	
Ethylene CH ₂ =CH ₂			20	A	A	A	A									A
Ethylene dibromide CH ₂ Br-CH ₂ Br				B		A	A									F
Ethylene dichloride CH ₂ ClCH ₂ Cl	dr mo	100	20	A	C	C	C	B	A			A		A	A	A
Ethylene glycol CH ₂ OH-CH ₂ OH		100	20	A	A	A	A	A	B	A	A	A	A	A	A	A
Exhaust gases <i>see combustion gases</i>																
Fats				A	A	A	A	A	A	A	A	A	A	A	A	A
Fatty acid C ₁₇ H ₃₅ COOH	100 100 100 100 100	20 60 150 180 300		A F F F F	A A A A A	A A A A A	A A A A A	A A A A A	A A A A A	B A B B	B B B B	A B A A A	A A A A A	A A A A A	A B A A F	A F F F F
Fixing salt <i>see sodium thiosulphate</i>																
Flue gases <i>see combustion gases</i>																
Fluorine	mo dr dr dr	100 200 100 500	20 20 20 20	F A A F	F A A A	F A A C	F A A C					A A A A	A A A A	F A A A	F F F F	F F F F
Fluorosilicic acid H ₂ (SiF ₆)		100 25 70	20 20 20	F F F	F F F	F F F	F F F	B B B	B B B	F B B	B B B	F B B	F E	F F F	F F F	F F F
Formaldehyde CH ₂ O	hy hy hy	10 40 all	20 20 bp	F F F	A A A	A A A	A A A	A A A	A A A	A A A	A A A	A A A	A A A	A A A	B B F	B B F
Formic acid HCOOH		10 10 80 85	20 bp bp 65	F F F F	F F F F	B B F F	A B A A	A B A A	A A A A	B B F E		A A F F	A A F F	A A F F	A A F F	A A F F

Medium				Materials												
Designation Chemical Formula	Concentration		Temperature	Stainless Steels			Nickel Based Alloys				Copper Based Alloys		Pure Metals			
	%	°C		Non/Low Alloy Steels			Incoloy 825 2.4858	Inconel 600 2.4816	Inconel 625 2.4856	Hastelloy-C 2.4610 C276 2.4819	Monel 2.4360	Alloy CuNi 70/30	Bronze	Titanium	Tantalum	Aluminum
			409, 410L, 430	SS304, SS321	SS316, SS316L											
Fuels																
Benzene			20 bp	A	A	A	A	A	A	A	A	A	A	A	A	A
Benzene-alcohol-mixture			20	A	A	A	A	A	A	A	A	A	A	A	A	A
Diesel oil			20	A	A	A	A	A	A	A	A	A	A	A	A	A
Furfural		100	25 bp	B F	B B	B B	B B				A	A	A	A	A	A
Galic acid C ₆ H ₄ (OH) ₃ COOH	hy	1 100	20 bp	B F	A A	A A	A A			F	A				A	A
Gelatine			20 80	A B	A A	A A	A A			A	A	A	A	A	A	A
Glacial acetic acid CH ₃ CO ₂ H <i>see acetic acid</i>																
Glass	me		1200	B		B	B									
Glauber salt <i>see sodium sulphate</i>																
Gluconic acid CH ₂ OH(CHOH) ₄ -COOH		100	20	B	A	A	A	A	A	A	A	A	A	A	A	A
Glucose C ₆ H ₁₂ O ₆	hy		20		A	A	A				A	A	A	A	A	A
Glutamic acid HOOC-CH ₂ -CH ₂ -CHNH ₂ -COOH			20 80	B F	C C	C C	A A	A	B	A	A	B				
Glycerine CH ₂ OH-CHOH-CH ₂ OH		100	20 bp	A B	A B	A A	A A	A	A	A	A	A	A	A	A	A
Glycol <i>see ethylene glycol</i>																
Glycolic acid CH ₂ OH-COOH			20 bp	F F	B F	B F	B F				A	A		A	B	B
Glystantine <i>see antifreeze</i>																
Hexachloroethane CCl ₃ -CCl ₃			20				A	A	A	A	A	A	A	A	A	F
Hexamethylene - tetramine (CH ₂) ₆ N ₄	hy hy	20 80	60 60	B F			A A				A	A				
Household ammonia <i>see ammonium hydroxide</i>																
Hydrazene H ₂ N-NH ₂			20	A			A		F	F			F			B
Hydrazine sulphate (NH ₂) ₂ H ₂ SO ₄	hy		10 bp	F			F	F								
Hydrobromic acid aqueous solution of hydrogen bromide (HBr)			20	F	F	F	F	F	F	F	F	F	F	F	F	F
Hydrochloric acid HCl		0.2 0.5 0.5 1 2 5 15 32 32	20 20 20 bp 20 65 20 20 20 bp	F F F F F F F F F	F F F F F F F F F	F F F F F F F F F	F F F F F F F F F				A A A A A A A A A	B F F F F	F F F F F	A A A A A A A A A	F F F F F	F F F F F
Hydrochloric-acid gas <i>see hydrogen chloride</i>																
Hydrofluoric acid HF		10 80 80 90	20 bp bp 30	F B	F	F	F	F	B	B	A	B	B	B	F	F

Corrosion Resistance Tables

Designation Chemical Formula	Medium		Materials															
	Concentration %	Temperature °C	Stainless Steels			Nickel Based Alloys				Copper Based Alloys		Pure Metals						
			Non/Low Alloy Steels			Incoloy 825 2.4858	Inconel 600 2.4816	Inconel 625 2.4856	Hastelloy-C 2.4610 C276 2.4819	Monel 2.4360	Alloy CuNi 70/30	Bronze	Titanium	Tantalum	Aluminium			
			409, 410L, 430	SS304, SS321	SS316, SS316L													
Hydrogen H		<-300 >300	A F	A A	A A	A A	A A	A A	A A									
Hydrogen bromide HBr	dr mo	100 30	20 20	F F	A A	F F	A A	F F	A A	A A	A A							A
Hydrogen chloride HCl	dr dr dr dr		20 100 250 500	A A B F	F F F F	B B F F	A A A A	A A A A	A A A A									B B F F
Hydrogen cyanide HCN	dr hy hy	20 cs	20 20	F F	A B	A B	A A	A A	A A	A A	B F	F F	F F	A A	A A	A A	A A	A A
Hydrogen fluoride HF		5 100	20 500	F F	F F	F F	F F	F F	A A	A A	A A	F F	F F	F F	F F	F F	F F	F F
Hydrogen peroxide H ₂ O ₂		all	20	F	F	A	A	A	B	A	A	B	F	F	B	F	A	
Hydrogen sulphide H ₂ S	dr dr dr mo	100 100 100 100	20 100 200 200	B F F F	D D F F	A A A A	A A A A	A A A A	A A	B		A	B	A	A	A	A	A
Hydroiodic acid	dr mo		20 20	A F	F F	F F	F F											
Hypochlorous acid HOCl			20	F	F	F	F											F
Indol			20	A	A	A	A	A	A	A	A	A	A	A	A	A	A	A
Ink <i>see gallic acid</i>																		
Iodine I ₂	dr mo mo	100	20 bp	F F	C F	C F	C F					A B B	F F	F F	F A			A F F
Iodoform CHI ₃	dr mo		60 20	F A	F C	A C	A C											A
Iron (II) chloride FeCl ₂	hy hy	10 cs	20	A		C	C					B	F	B	B	A	A	F
Iron (II) sulphate FeSO ₄	hy	all	bp	A	A	A	A					A	A					F
Iron (III) chloride FeCl ₃	dr hy hy hy	100 5 10 50	20 25 65 50	A F F F	C F B F	C F B F	C F B F	B F F F	A A F B	F F F F	F F F F	A A A A	A A A A	A A A A	A A A A	B B B B		
Iron (III) nitrate Fe(NO ₃) ₃	hy hy	10 all	bp	F A	A A	A A	A A	F F	F F	F F	F F	A A	A A					
Iron (II) sulphate FeSO ₄	hy	all	bp	A	A	A	A					A	A					A
Iron (III) sulphate Fe(SO ₄) ₃	hy hy	<-30 all	20 bp	F F	A B	A A	A A	A A	F A			A A	B F	F F	F A	A A	A A	F F
Isatine C ₈ H ₆ NO ₂			20	B	A	A	A	A	A	A	A	A	A	A	A	A	A	A
Kalinite <i>see alum</i>																		
Ketene R ₂ C=C=O			20 bp		A	A	A	A	A	A	A	A	A	A	A	A	A	A
Lactic acid C ₃ H ₅ O ₃	hy hy hy hy	1 all 10 all	20 20 bp bp	F F F F	F F F F	A B F B	A A F B	A A A A	A A A A	A A A A	A A A A	A A A A	A A A A	A A A A	A A A A	A A A A	A A A A	
Lactose C ₁₂ H ₂₂ O ₁₁	hy		20	A	A	A	A	A	A	A	A	A	A	A	A	A	A	A
Lead Pb	me		388 900	F F	B F	B F	B F		A									A
Lead acetate (CH ₃ -COO) ₂ Pb	me			F	A	A	A					A	A	F				F
Lead acide Pb(NO ₃) ₂			<-20 <-30						A	A	A		B					

Designation Chemical Formula	Medium		Materials															
	Concentration %	Temperature °C	Stainless Steels			Nickel Based Alloys				Copper Based Alloys		Pure Metals						
			Non/Low Alloy Steels			Incoloy 825 2.4858	Inconel 600 2.4816	Inconel 625 2.4856	Hastelloy-C 2.4610 C276 2.4819	Monel 2.4360	Alloy CuNi 70/30	Bronze	Titanium	Tantalum	Aluminium			
			409, 410L, 430	SS304, SS321	SS316, SS316L													
Lead nitrate Pb(NO ₃) ₂	hy		100	B	A	A	A	A	A	A	A	A	A	A	A	A	A	A
Lime CaO <i>see calcium oxide</i>																		
Lithium Li	me		300	A	A	A	A	A	A	A	A	A	A	F	F	F	A	F
Lithium chloride LiCl	hy	cs		F	F	F	C	A	A	A	A	A	B				A	
Lithium hydroxide LiOH	hy	all	20	B	A	A	A	A	A	A	A	A	A	A				A
Magnesium Mg	me		650		B	F	F	F	F		F	F	F	F	F	F	A	A
Magnesium carbonate MgCO ₃	hy hy		20 bp	A A	A A	A A	A A	A A	A A	A A	A A	A A	A A	A A	A A	A A	A A	B B
Magnesium chloride MgCl ₂	hy hy hy	5 5 50	20 bp bp	F F F	F F F	C C F	C C F	A A A	A A A	A A A	A A A	A A A	A A A	A A A	F F F	A A A	A A A	
Magnesium hydroxide Mg(OH) ₂	hy hy	cs sa		A	A	A	A	A	A	A	A	A	A	A	A	A	A	F
Magnesium nitrate Mg(NO ₃) ₂		cs		A	A	A	A	F	F		F	A	F	A	A	A	A	B
Magnesium oxide <i>see magnesium hydroxide</i>																		
Magnesium sulphate MgSO ₄	hy hy hy	0.1 5 50	20 20 bp	A F F	B B A	A A A	A A A	A	B	A	A	A	B	A	A	A	A	F A A
Maleic acid HOOC-CH=CH-COOH	hy hy	5 50	20 100	F F	A A	A A	A A	A	B	A	A	A	B	A				A A
Maleic anhydride		100	285											A				
Mallic acid	hy hy		20 100	F F	F F	A A	A A	A A	B A	A A	A A	B F	F F	A A	A A	A A	A A	
Malonic acid CH ₂ (COOH) ₂			20 50 100									B	B	B	B	B	B	B
Manganese(II) chloride MnCl ₂	hy hy	5 50	100 20	F B	C C	C C	C C	B B	B B	B B		B B	F F	A A	A A	A A	A A	
Manganese(II) sulphate MnSO ₄		cs			A	A	A	A	A	A	A	A	A					A
Maritime climate	mo			EC	BC	BC	BC	A	A	A	A	A	A	A	A	A	A	A
Methanol <i>see methyl alcohol</i>																		
Menthol C ₁₀ H ₁₈ OH					A	A	A	A	A	A	A	A	A	A	A	A	A	A
Mercury Hg	dr	100	20 all	A B	C B	C B	C A		A	A	A	A	F	F	F	F	A	B
Methane CH ₄			200 600	A	A	A	A	A	A	A	A	A	A	A	A	A	A	A
Methyl acetate CH ₃ COOCH ₃			60 60	bp	A	A	A	A										A
Methyl alcohol CH ₃ OH			<100 100	bp	B	F	A	B	B	A	A	A	A	A	A	A	A	B
Methylamine CH ₃ -NH ₂	hy		25	20	B	A	A	A	A		A	A	F	F	F	F	A	A
Methyl chloride CH ₃ Cl	dr mo mo		20 20 bp	A F	A C	C C	C C		A	A	A	A	A	A	A	A	A	A
Methyldehyde <i>see formaldehyde</i>																		
Methylene dichloride CH ₂ Cl ₂	dr mo mo		20 20 bp	A	C	C	C	C	C	C	C	A	B	B	B	B	A	A

Metallic Hose Assemblies | Technical Data

Medium			Materials															
Designation Chemical Formula	Concentration Temperature	Non/Low Alloy Steels	Stainless Steels			Nickel Based Alloys				Copper Based Alloys		Pure Metals						
			409, 410L, 430	SS304, SS321	SS316, SS316L	Incoloy 825 2.4858	Inconel 600 2.4816	Inconel 625 2.4856	Hastelloy-C 2.4610 C276 2.4819	Monel 2.4360	Alloy CuNi 70/30	Bronze	Titanium	Tantalum	Aluminum			
																%	°C	%
Milk of lime Ca(OH) ₂		20 bp	A	B	A	A									A	A		
Milk sugar see lactose																		
Mixed acids HNO ₃ H ₂ SO ₄ H ₂ O % % % 90 10 - 50 50 - 50 50 - 50 50 - 38 60 2 25 75 - 25 75 - 15 20 65 15 20 65 10 70 20 10 70 20 05 30 65 05 30 65 05 30 65 05 15 80		20 20 90 120 50 50 90 157 20 80 50 90 20 90 134	A		A	A	A	A	A	A						B	F	
Molasses					A	A	A	A	A	A					A	A	A	
Monochloroacetic acid see chloroacetic acid																		
Naphthaline C ₁₀ H ₈		100 100	20 390		A	A	A	A							A		B	
Naphthaline chloride		100 100	45 200															
Naphthaline sulphonic acid C ₁₀ H ₇ SO ₃ H		100 100	20 bp		A	F	F	F										
Naphthenic acid	hy	100	20		C	C	C	A	A	A							A	
Nickel (II) chloride NiCl ₂	hy hy	10 10 tot	20 70		F	C	C	C	A	B	A	A	A	B	B	B	A	A
Nickel (II) nitrate Ni(NO ₃) ₂	hy hy	10 100	25 25		F	A	A	A	A	A	F	A	A	B	B	B	A	A
Nickel (II) sulphate NiSO ₄	hy hy		20 bp		F	A	A	A	A	B	B	B	B	B	B	B	A	A
Nitric acid HNO ₃		1 1 5 5 10 15 25 50 65 99 20 40	20 bp 20 bp 10 bp 25 bp 20 bp 290 200		F	A	A	A	A	A	A	A	A	A	A	A	A	F
Nitrobenzene C ₆ H ₅ (NO ₂) _y	hy				A	A	A	A	A	A	A	A	A	A	A	A	A	A
Nitrobenzoic acid C ₆ H ₄ (NO ₂)COOH	hy		20		B	A	A	A	A	A	A	A	A	A	A	A	A	A
Nitroglycerine C ₃ H ₅ (ONO ₂) ₃	hy		20		A	A	A	A										A
Nitrogen N		100 100	20 900		A	B			A	A	A	A	A	A	A	A	A	A
Nitrous acid HNO ₂ See nitric acid																		

Medium			Materials															
Designation Chemical Formula	Concentration Temperature	Non/Low Alloy Steels	Stainless Steels			Nickel Based Alloys				Copper Based Alloys		Pure Metals						
			409, 410L, 430	SS304, SS321	SS316, SS316L	Incoloy 825 2.4858	Inconel 600 2.4816	Inconel 625 2.4856	Hastelloy-C 2.4610 C276 2.4819	Monel 2.4360	Alloy CuNi 70/30	Bronze	Titanium	Tantalum	Aluminum			
																%	°C	%
Oleic acid see fatty acid																		
Oleum see sulphur trioxide																		
Oxalic acid C ₂ H ₂ O ₄	hy hy	all 10 sa	20 bp		F	F	F	F	B	B	A	A	A	B	B	B	A	A
Oxygen O			500		B	A	A	A						A		F		A
Ozone						A	A	A	A	A	A	A	A	A			A	A
Paraffin C _n H _{2n+2}	me		20 120		A	A	A	A						A	A	A	A	A
Perchloroethane see hexachlorethane																		
Perchloric acid (60%) HClO ₄		10 100	20 20		F	F	F	F									A	A
Perchloroethylene C ₂ Cl ₄	mo		20 bp		A	A	A	A	B	B	C	C	C			A	B	A
Perhydrol see hydrogen peroxide																		
Petroleum			20 bp		A	A	A	A	A	A				A	A	A	A	A
Petrol see benzine (benzene)																		
Phenol see carbolic acid																		
Phloroglucinol C ₆ H ₃ (OH) ₃			20			A	A	A	A	A	A	A	A	A			A	A
Phosgene COCl ₂	dr		20			A	A	A	A	A	A	A	A	A			A	A
Phosphoric acid H ₃ PO ₄	hy hy hy hy hy	1 10 30 60 80 80	20 bp 20 bp 20 bp		F	F	F	F	A	A	A	A	A	A	A	A	B	F
Phosphorous P	dr		20			A	A	A	A									
Phosphorous pentachloride PCl ₅	dr		20 200 bp		A		A	A	A	A	A	A	A				A	A
Phtalic acid and phtalic anhydride C ₆ H ₄ (COOH) ₂	dr		20 200 bp		A		A	A	A	A	A	A	A	A	A		A	A
Picric acid C ₆ H ₃ (OH)(NO ₂) ₃	hy hy me	3 cs	20 150		F	F	F	F	A	A	A	A	A	F	F		A	F
Plaster see calcium sulphate																		
Potash lye see potassium hydroxide																		
Potassium K	me		604 800		A		A	A	A					B	B		A	A
Potassium acetate CH ₃ -COOK	me hy		100 292 20		B	B	A	A	A	A				A	A	A	A	A
Potassium bisulphate KHSO ₄	hy hy		5 20 90		F	F	F	F	E	A	F	F					A	F
Potassium bitartrate KC ₄ H ₄ O ₆	hy hy	cs sa			F	F	F	F	F	F	F						A	A
Potassium bromide KBr	hy		5 30		F	C	C	C	C	A	B	A	A	A	B	A	A	A

Corrosion Resistance Tables

Medium				Materials												
Designation Chemical Formula	Concentration %	Temperature °C	Non/Low Alloy Steels	Stainless Steels			Nickel Based Alloys				Copper Based Alloys		Pure Metals			
				Non/Low Alloy Steels			Nickel Based Alloys				Copper Based Alloys		Pure Metals			
				409, 410L, 430	SS304, SS321	SS316, SS316L	Incoloy 825 2.4858	Inconel 600 2.4816	Inconel 625 2.4856	Hastelloy-C 2.4610 C276 2.4819	Monel 2.4360	Alloy CuNi 70/30	Bronze	Titanium	Tantalum	Aluminium
Potassium carbonate K ₂ CO ₃	hy hy	50 50	20 bp	F F	A A	A A	A A	A A	A A	A A	A A	A A	A A	A A	A A	F F
Potassium chlorate KClO ₃	hy hy	5 sa	20 sa	F F	A A	A A	A A	A A	A A	A A	A A	A A	A A	A A	A A	A A
Potassium chloride KCl	hy hy hy hy hy	10 10 30 cs sa	20 -bp bp bp sa	F F F F F	F F F F F	C C C C C	C C C C C	A A A A A	A A A A A	A A A A A	A A A A A	A A A A A	A A A A A	A A A A A	A A A A A	B B B B B
Potassium chromate K ₂ CrO ₄	hy hy	10 hy	20 bp	A B	A A	A A	A A	A A	A A	A A	A A	A A	A A	A A	A A	A A
Potassium cyanide KCN	hy hy	10 20	20 bp	F F	A A	A A	A A	A A	F F	A A	B B	F F	F F	A A	F F	F F
Potassium dichromate K ₂ Cr ₂ O ₇	hy hy hy	10 25 40	40 25 bp	F F F	F F F	A A A	A A A	B B B	B B B	B B B	B B B	B B B	A A A	F F F	B B B	A A A
Potassium ferricyanide K ₃ (Fe(CN) ₆)	hy hy hy	1 cs sa	20 sa	A F	A A C	A A A	A A A	B A A	B A A	A A A	A A A	A A A	A A A	A A A	A A A	A A A
Potassium ferrocyanide K ₄ (Fe(CN) ₆)	hy hy hy	1 25 25	20 bp	A B	A A B	A A A	A A A	B A A	B A A	A A A	A A A	A A A	A A A	A A A	A A A	A A A
Potassium fluoride KF	hy hy	cs sa	sa	A B	A A	A A	A A	A A	A A	A A	A A	A A	A A	A A	A A	F F
Potassium hydroxide	hy hy hy hy hy hy me	10 20 30 50 sa 100	20 bp bp bp sa 360	A D D D D F	A D D D D F	D D D D D F	D D D D D F	B B B B B B	B B B B B B	B B B B B B	B B B B B B	A A A A A A	A A A A A A	A A A A A A	F F F F F F	F F F F F F
Potassium hypochlorite KClO	hy hy	all all	20 bp	C C	C C	C C	C C	F F	F F	A B	F F	F F	A A	A A	A A	F F
Potassium iodide KI	hy hy	20 bp	bp	A C	C C	C C	C C	A B	B B	A A	F F	A A	A A	A A	A A	F F
Potassium nitrate KNO ₃	hy hy	all all	20 bp	A A	A A	A A	A A	B B	B B	B B	B B	A A	A A	A A	A A	B B
Potassium nitrite KNO ₂	all	bp	bp	B	A	A	A	B	A	A	A	A	B	B		
Potassium permanganate KMnO ₄	hy hy	10 all	20 bp	A F	A B	A B	A B	A A	B B	B B	A B	B B	A A	A A	A A	A A
Potassium persulphate K ₂ S ₂ O ₈	hy	10	50	F	F	A	A	A	A	A	A	F	F	A	F	F
Potassium silicate K ₂ SiO ₃		20	bp	B	A	A	A	A	A	A	A	A	A	A	A	F
Potassium sulphate K ₂ SO ₄	hy hy	10 all	25 bp	F A	A A	A A	A A	A A	A A	A A	A A	A A	A A	A A	A A	A B
Protein solutions		20	bp	B	A	A	A	A	A	A	A	A	A	A	A	A
Pyridine C ₅ H ₅ N	dr	all	bp	A	A	A	A	A	A	A	A	A	A	A	A	A
Pyrogallol C ₃ H ₃ (OH) ₃	all all	20 bp	bp	F A	A A	A A	A A	A A	A A	A A	A A	A A	A A	A A	A A	A A
Quinine bisulphate	dr	20	bp	F	F	F	A	A	A	A	B	A	A	A	A	A
Quinine sulphate	dr	20	bp	F	A	A	A	A	A	A	B	A	A	A	A	A
Quinol HO-C ₆ H ₄ -OH				F	A	A	A	A	A	A	B	A	A	A	A	A
Salicylic acid HO-C ₆ H ₄ -COOH	dr mo hy	100 100 cs	20 bp	B F F	A A A	A A A	A A A	B A A	A A A	A A A	A A A	A A A	A A A	A A A	A A A	A B
Salmiac see ammonium chloride																

Medium				Materials												
Designation Chemical Formula	Concentration %	Temperature °C	Non/Low Alloy Steels	Stainless Steels			Nickel Based Alloys				Copper Based Alloys		Pure Metals			
				Non/Low Alloy Steels			Nickel Based Alloys				Copper Based Alloys		Pure Metals			
				409, 410L, 430	SS304, SS321	SS316, SS316L	Incoloy 825 2.4858	Inconel 600 2.4816	Inconel 625 2.4856	Hastelloy-C 2.4610 C276 2.4819	Monel 2.4360	Alloy CuNi 70/30	Bronze	Titanium	Tantalum	Aluminium
Salpetre see potassium nitrate																
Seawater at flow velocity v (m/s) 0 < v ≤ 1.5 1.5 < v < 4.5		20 20	B B	C A	C A	C A	C A	C A	C A	A A	B A	B A	B A	B A	F A	F A
Siliceous flux acid see fluorsilicic acid																
Silver nitrate AgNO ₃	hy hy hy hy me	10 10 20 40 100	20 bp 60 20 250	F F F F F	A A A A A	A A A A A	A A A A A	A A A A A	A A A A A	A A A A A	A A A A A	A A A A A	A A A A A	A A A A A	A A A A A	F F F F F
Soap	hy hy hy	1 1 10	20 75 20	A A A	A A A	A A A	A A A	A A A	A A A	A A A	A A A	A A A	A A A	A A A	A A A	A A A
Sodium (O ₂ 0.005 %) Na	me	200 600	600	A F	A B	A A	A A	A A	A A	A A	A A	A A	A A	A A	A A	B B
Sodium acetate CH ₃ -COONa	hy hy	10 sa	25 bp	F F	A A	A A	A A	A A	A A	A A	A A	A A	A A	A A	A A	A A
Sodium aluminate Na ₂ AlO ₃	hy	100 10	20 25	A A	A A	A A	A A	A A	A A	A A	A A	A A	A A	A A	A A	F F
Sodium arsenate Na ₂ HAsO ₄	hy	cs	sa	A	A	A	A	A	A	A	A	A	A	A	A	A
Sodium bicarbonate NaHCO ₃	hy hy hy	100 10 cs sa	20 20	A A	A A	A A	A A	A A	A A	A A	A A	A A	A A	A A	A A	A B
Sodium bisulphate NaHSO ₄	hy hy	all all	20 bp	F F	F F	F F	F F	A B	A B	B B	B B	B B	B B	B B	F F	B B
Sodium bisulphite NaHSO ₃	hy hy hy	10 50 50	20 bp	F F F	F F F	F F F	F F F	A A A	A A A	A A A	A A A	A A A	A A A	A A A	A A A	A A A
Sodium borate Na ₂ B ₄ O ₇ 4 H ₂ O	hy me	cs	sa	F	A	F	A	F	A	F	A	F	A	F	A	B
Sodium bromide NaBr	hy hy	all all	20 bp	F F	F F	F F	F F	F C	F C	F C	F C	F C	F C	F C	F C	F F
Sodium carbonate Na ₂ CO ₃	hy hy hy me	B all 400 900	20 bp	F F F	A A F F	A A F F	A A F F	A A A A	A A A A	A A A A	A A A A	A A A A	A A A A	A A A A	A A A A	E F
Sodium chloride NaCl	hy hy hy	0.5 2 cs sa	20 20	F F	C C C	C C C	C C C	C C C	C C C	A A A	B B B	A A A	A A A	A A A	A A A	A E F
Sodium chlorite NaClO ₂	dr hy hy hy	100 5 5 80	20 bp	F F	C F F	C F F	C F F	A A	A A	A A	A A	A A	A A	A A	A A	A A
Sodium chromate Na ₂ CrO ₄	hy	all	bp	A	A	A	A	A	A	A	A	A	A	A	A	A
Sodium cyanide NaCN	me hy	600 B	B B	A	A	A	A	A	A	A	A	A	A	A	F F	F F
Sodium fluoride NaF	hy hy hy	10 10 cs	20 bp	A A	A A	A D	A D	A D	A D	A D	A D	A D	A D	A D	A D	A D
Sodium hydrogensulphate see sodium bisulphate																
Sodium hydrogensulphite see sodium bisulphite																

Metallic Hose Assemblies | Technical Data

Medium				Materials																
Designation Chemical Formula	Concentration Temperature	Stainless Steels										Copper Based Alloys	Pure Metals							
		Non/Low Alloy Steels																		
		%	°C	409, 410L, 430	SS304, SS321	SS316, SS316L	Incoloy 825 2.4858	Inconel 600 2.4816	Inconel 625 2.4856	Hastelloy-C 2.4610 C276 2.4819	Monel 2.4360			Alloy CuNi 70/30	Bronze	Titanium	Tantalum	Aluminum		
Sodium hydroxide NaOH	solid	100	all	A	A	A	A	A	A	A	A	A	A							
	hy	<10	<60	A	A	A	A	A	A	A	A	A	A							
	hy	<10	<60	A	A	A	A	A	A	A	A	A	A							
	hy	<20	<60	A	A	A	A	A	A	A	A	A	A							
	hy	<20	<60	A	A	A	A	A	A	A	A	A	A							
	hy	<40	<60	A	A	A	A	A	A	A	A	A	A							
	hy	<40	<100	A	A	A	A	A	A	A	A	A	A							
	hy	<50	<60	A	A	A	A	A	A	A	A	A	A							
	hy	<50	<100	A	A	A	A	A	A	A	A	A	A							
	hy	<50	<100	A	A	A	A	A	A	A	A	A	A							
Sodium hypochlorite NaOCl	hy	5	10	F	F	F	C	C	A	F	A								F	
Sodium hyposulphite Na ₂ S ₂ O ₄	all	all	20	bp	F	F	A	A	A	A	B	B	B	B	F	F				A
Sodium iodide NaI					C	C	C	C	A	A	A	A								B
Sodium nitrate NaNO ₃	hy	5	20	F	A	A	A	A	A	A	A	A	B	A	B					A
	hy	10	20	F	A	A	A	A	A	A	A	A	B	A	B					A
	hy	<10	20	bp	F	A	A	A	A	A	A	A	B	A	B					A
	hy	30	20	bp	F	A	A	A	A	A	A	A	B	A	B					A
	hy	30	bp	bp	F	A	A	A	A	A	A	A	B	A	B					A
	me	30	320	F	A	A	A	A	A	A	A	A	B	A	B					A
Sodium nitrite NaNO ₂	hy		20		A	A	B	A	A	A	A	A								B
Sodium perborate NaBO ₂	hy	10	20	F	A	A	A	A				B								B
	hy	10	bp	F	A	A	A	A				B								B
Sodium perchlorate NaClO ₄	hy	10	20	F	F	A	A	B				B								A
	hy	10	bp	F	F	A	A	B				B								A
Sodium peroxide Na ₂ O ₂	hy	10	20	F	B	A	A	B	B	B	B	B	A	F	F					F
	me	10	bp	460	F	F	A	A	B	B	B	B	A	F	F					F
Sodium phosphate Na ₂ HPO ₄	hy	10	20		A	A	A	A	A	A	A	A	A	A	B					A
	hy	10	bp		A	A	A	A	A	A	A	A	A	A	B					A
	hy	cs			A	A	A	A	A	A	A	A	A	A	B					A
Sodium salicylate C ₇ H ₅ (OH)COONa	hy	all	20		A	A	A	A	A			A								A
Sodium silicofluoride Na ₂ (SiF ₆)	hy	cs			F	F	F	F	A	A	B	B	A							B
Sodium sulphate Na ₂ SO ₄	hy	10	20	F	A	A	A	A	A	A	A	A	A	A	A					A
	hy	cs	20	F	B	A	A	A	A	A	B	A	A	A	A					A
	hy	sa	20	F	F	A	A	A	A	A	A	A	A	A	A					B
Sodium sulphide Na ₂ S	hy	1	20	F	A	A	A	A	A	A	B									B
	hy	cs	20	F	F	F	F	A	A	B	A									F
	hy	sa	20	F	F	F	F	B	A	A										F
Sodium sulphite Na ₂ SO ₃	hy	10	20	F	B	A	A	A					A	B	B					A
Sodium superoxide see sodium peroxide																				
Sodium tetraborate see borax																				
Sodium thiosulphate Na ₂ S ₂ O ₃	hy	1	20	B	A	A	A	A					A							A
	hy	10	20	F	A	A	A	A												A
	hy	25	bp	F	C	C	C	C												A
Spirit of turpentine		100	20	F	A	A	A	A												A
		100	bp	F	A	A	A	A												A
Spirits			20	B	F	A	A	A	A	A	A	A	A							A
			bp	F	A	A	A	A	A	A	A	A	A							A
Steam 02 < 1 ppm; Cl < 10 ppm 02 > 1 ppm; Cl < 10 ppm 02 > 15 ppm; Cl < 3 ppm			<560	B	B	B	B	A												A
			<315	D	D	D	D	D												A
			>450	D	D	D	D	D												A

Medium				Materials																
Designation Chemical Formula	Concentration Temperature	Stainless Steels										Copper Based Alloys	Pure Metals							
		Non/Low Alloy Steels																		
		%	°C	409, 410L, 430	SS304, SS321	SS316, SS316L	Incoloy 825 2.4858	Inconel 600 2.4816	Inconel 625 2.4856	Hastelloy-C 2.4610 C276 2.4819	Monel 2.4360			Alloy CuNi 70/30	Bronze	Titanium	Tantalum	Aluminum		
Stearic acid CH ₃ (CH ₂) _n COOH	100	20	B	F	A	A	A	A	A	A	A	A	A	A	A	A	A	A	A	A
	100	95	180	F	A	A	A	A	A	A	A	A	A	A	A	A	A	A	A	F
Succinic acid HOOC-CH ₂ -CH ₂ -COOH		bp	B	A	A	A	A	A	A	A	A	A	A	A	A	A	A	A	A	
Sulphur S	dr	100	60	A	A	A	A	A	A	A	A	A	A	A	A	A	A	A	A	A
	me	130	240	F	F	F	F	F	F	F	F	F	F	F	F	F	F	F	F	F
	me	20	20	F	F	F	F	F	F	F	F	F	F	F	F	F	F	F	F	F
	me	20	20	F	F	F	F	F	F	F	F	F	F	F	F	F	F	F	F	F
Sulphur dioxide SO ₂	dr	100	20	A	F	F	F	F	F	F	F	F	F	F	F	F	F	F	F	A
	dr	100	60	F	F	F	F	F	F	F	F	F	F	F	F	F	F	F	F	A
	dr	100	400	F	F	F	F	F	F	F	F	F	F	F	F	F	F	F	F	A
	dr	100	800	F	F	F	F	F	F	F	F	F	F	F	F	F	F	F	F	A
	mo	100	20	F	F	F	F	F	F	F	F	F	F	F	F	F	F	F	F	A
	mo	100	60	F	F	F	F	F	F	F	F	F	F	F	F	F	F	F	F	F
Sulphuric acid H ₂ SO ₄	0.05	20	F	B	A	A	A	A	A	A	A	A	A	A	A	A	A	A	A	B
	0.05	bp	F	F	F	F	F	F	F	F	F	F	F	F	F	F	F	F	F	F
	0.1	20	F	F	F	F	F	F	F	F	F	F	F	F	F	F	F	F	F	F
	0.2	bp	F	F	F	F	F	F	F	F	F	F	F	F	F	F	F	F	F	F
	0.8	bp	F	F	F	F	F	F	F	F	F	F	F	F	F	F	F	F	F	F
	1	20	F	F	F	F	F	F	F	F	F	F	F	F	F	F	F	F	F	F
	3	bp	F	F	F	F	F	F	F	F	F	F	F	F	F	F	F	F	F	F
	5	bp	F	F	F	F	F	F	F	F	F	F	F	F	F	F	F	F	F	F
	7.5	20	F	F	F	F	F	F	F	F	F	F	F	F	F	F	F	F	F	F
	10	bp	F	F	F	F	F	F	F	F	F	F	F	F	F	F	F	F	F	F
	25	20	F	F	F	F	F	F	F	F	F	F	F	F	F	F	F	F	F	F
	25	bp	F	F	F	F	F	F	F	F	F	F	F	F	F	F	F	F	F	F
	40	20	F	F	F	F	F	F	F	F	F	F	F	F	F	F	F	F	F	F
	40	bp	F	F	F	F	F	F	F	F	F	F	F	F	F	F	F	F	F	F
	50	20	F	F	F	F	F	F	F	F	F	F	F	F	F	F	F	F	F	F
	50	bp	F	F	F	F	F	F	F	F	F	F	F	F	F	F	F	F	F	F
	60	20	F	F	F	F	F	F	F	F	F	F	F	F	F	F	F	F	F	F
	80	20	F	F	F	F	F	F	F	F	F	F	F	F	F	F	F	F	F	F
	90	20	F	F	F	F	F	F	F	F	F	F	F	F	F	F	F	F	F	F
	96	20	F	F	F	F	F	F	F	F	F	F	F	F	F	F	F	F	F	F
Sulphurous acid H ₂ SO ₃	hy	1	20	F	F	F	F	F	F	F	F	F	F	F	F	F	F	F	F	F
	hy	cs	20	F	F	F	F	F	F	F	F	F	F	F	F	F	F	F	F	F
Sulphur trioxide SO ₃	hy	100	20	A																F
	dr	100	20	A																F
Tannic acid C ₇₆ H ₅₂ O ₄₆	hy	5	20	F	F	A	A	A	A	A	A	A	A	A	A	A	A	A	A	A
	hy	25	100	F	F	F	F	F	F	F	F	F	F	F	F	F	F	F	F	F
	hy	50	bp	F	F	F	F	F	F	F	F	F	F	F	F	F	F	F	F	F
Tar			20	A	A	A	A	A												B
Tartaric acid	hy	10	20	B	F	A	A	A	A	A	A	A	A	A	A	A	A	A	A	F
	hy	10	bp	F	B	A	A	A	A	A	A	A	A	A	A	A	A	A	A	F
	hy	25	20	F	F	F	F	F	F	F	F	F	F	F	F	F	F	F	F	F
	hy	25	bp	F	F	F	F	F	F	F	F	F	F	F	F	F	F	F	F	F
	hy	50	20	F	F															

Corrosion Resistance Tables

Medium			Materials															
Designation Chemical Formula	Concentration	Temperature	Stainless Steels			Nickel Based Alloys					Copper Based Alloys		Pure Metals					
	%	°C	Non/Low Alloy Steels	409, 410L, 430	SS304, SS321	SS316, SS316L	Incoloy 825 2.4858	Inconel 600 2.4816	Inconel 625 2.4856	Hastelloy-C 2.4610 C276 2.4819	Monel 2.4360	Alloy CuNi 70/30	Bronze	Titanium	Tantalum	Aluminium		
Trichloromethane <i>see chloroform</i>																		
Tricresylphosphate			A	A	A	A	A	A	A	A								
Trinitrophenol <i>see picric acid</i>																		
Trichloroacetic acid <i>see chloroacetic acid</i>																		
Urea CO(NH ₂) ₂	100	20	A	A	A	A				A	A			A	A	A	A	
	100	150	F	F	B	A		F		B	A			A	A	A	F	
Uric acid C ₅ H ₄ O ₃ N ₃	hy	20	F	A	A	A	A	A	A	A	A	A	A	A	A	A	A	F
	hy	100	F	A	A	A	A	B	A	A	A	A	A	A	A	A	A	F
Vinyl chloride CH ₂ =CHCl	dr	-20	A	A	A	A				A			A					A
		-400	A	A	A	A				A			A					A
Water vapour <i>see steam</i>																		
Wine		20	F	A	A	A		A					F		A	A	F	F
		bp	F	A	A	A		A					F		A	A	F	F
Yeast		20	B	A	A	A	A	A	A	A	A	A	A	A	A	A	A	A
Yellow potassium prussiate <i>see potassium ferricyanide</i>																		
Zinc chloride ZnCl ₂	hy	5	20	F	C	C	C	A	B	A	A	B	F	F	A	A	F	F
	hy	5	bp	F	C	C	C	A	B	A	A	B	F	F	A	A	F	F
	hy	10	20	F	C	C	C	A	B	A	A	B	F	F	A	A	F	F
	hy	20	20	F	C	C	C	A	B	A	A	B	F	F	A	A	F	F
	hy	75	20	F	C	C	C	A	B	A	A	B	F	F	A	A	F	F
Zinc sulphate ZnSO ₄	hy	2	20	F	A	A	A			A	A	A	A	A	A	A	A	A
	hy	30	bp	F	A	A	A			A	A	A	A	A	A	A	A	A
	hy	30	bp	F	A	A	A			A	A	A	A	A	A	A	A	A
	hy	cs		F	A	A	A	A	A	A	A	A	A	A	A	A	A	A
	hy	sa		F	A	A	A	A	A	A	A	A	A	A	A	A	A	A

Material Selection At A Glance

Thorburn’s metal hose assemblies are typically made from austenitic stainless steel

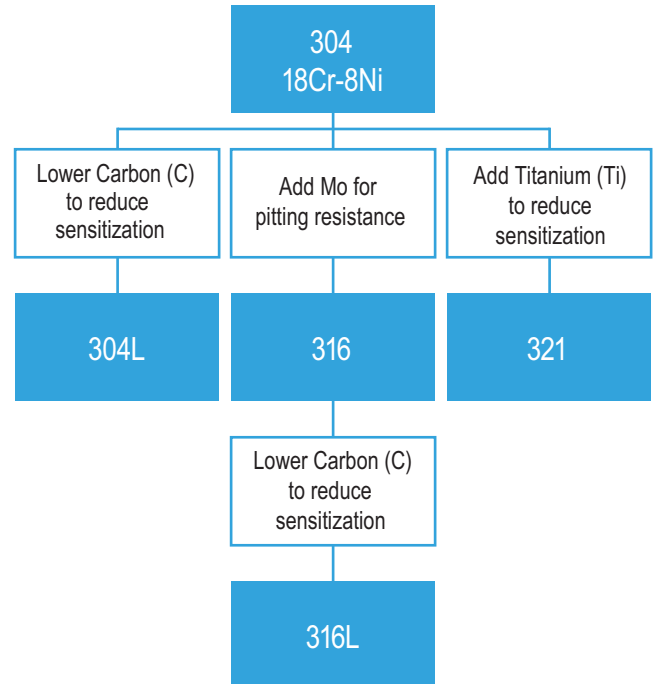

Thorburn’s austenitic materials is compliant with NACE MR0175-2009/ISO 15156-2009

T-300 Series Stainless Steel (Austenitic)

Thorburn’s metal hose is typically made from austenitic stainless steel, such as, 304, 304L, 316, 316L & 321

T-304 Stainless Steel UNS S30400 / EN 1.4301

T-304 is the most commonly used stainless in the world and is referred to as 18/8. It is weldable, machinable with the right techniques, and has good corrosion resistance.

T-304L Stainless Steel UNS S30403 / EN 1.4307

T-304L has reduced or low carbon to eliminate carbide precipitation due to welding so the alloy can be used in the “as welded” condition even in severe corrosive conditions.

T-316 Stainless Steel UNS S31600 / EN 1.4401

T316 stainless steel is 18/8 with the inclusion of molybdenum (Mo) in the alloy. To give better overall corrosion resistant properties than Grade 304, particularly higher resistance to pitting and crevice corrosion in chloride environments.

T-316L Stainless Steel UNS S31603 / EN 1.4404

T-316L has reduced or low carbon to eliminates carbide precipitation and offers higher creep, stress to rupture and tensile strength at elevated temperatures.

T-321 Stainless Steel UNS S32100 / EN 1.4541

Type 321 is an austenitic chrome nickel steel stabilized with titanium. This material has similar properties to alloy 304, but its titanium content limits carbide precipitation, making it somewhat easier to machine. This grade is recommended for parts fabricated by welding which cannot be subsequently annealed.

In-House Testing Technology



Flex-Impulse Testing Up To 700 BAR @ 150°C Testing Standards & Certification

Impulse Testing:

CSA N285.0, SAE J343, ISO 6803, ISO 6605 Peak: ISO 6772

Flex-Impulse Testing:

ISO 8032 (Half Omega), SAE J1405/ISO 6802 (Full Omega)



Burst Testing Up To 4000 BAR

Testing Standards & Certification

SAE J343, DIN 20024, ISO 7241/2, ISO 1402 (Variation in length), ASME B31.1, ASME B31.3, ASME Sec VIII, ASME Sec III CSA B51



Life Cycle Testing

Testing Standards & Certification

ISO 10380



Proof Testing Up To 6 Hoses 1000 BAR

Testing Standards & Certification

SAE J343, DIN 20024, ISO 7241/2, ISO 1402 (Variation in length), ASME B31.1, ASME B31.3, ASME Sec VIII, ASME Sec III CSA B51

THORBURN FLEX - Canada
 165 Oneida, Pointe-Claire, Quebec
 Canada, H9R 1A9
 Tel: +1-514-695-8710
 Fax: +1-514-695-1321
 sales@thorburnflex.com



ISCIR Romania | CNCAN Romania | EN 13480-2002 | HAF 604 China | TSG China
 (CRN for all Canadian Provinces)

Thorburn's Global Presence

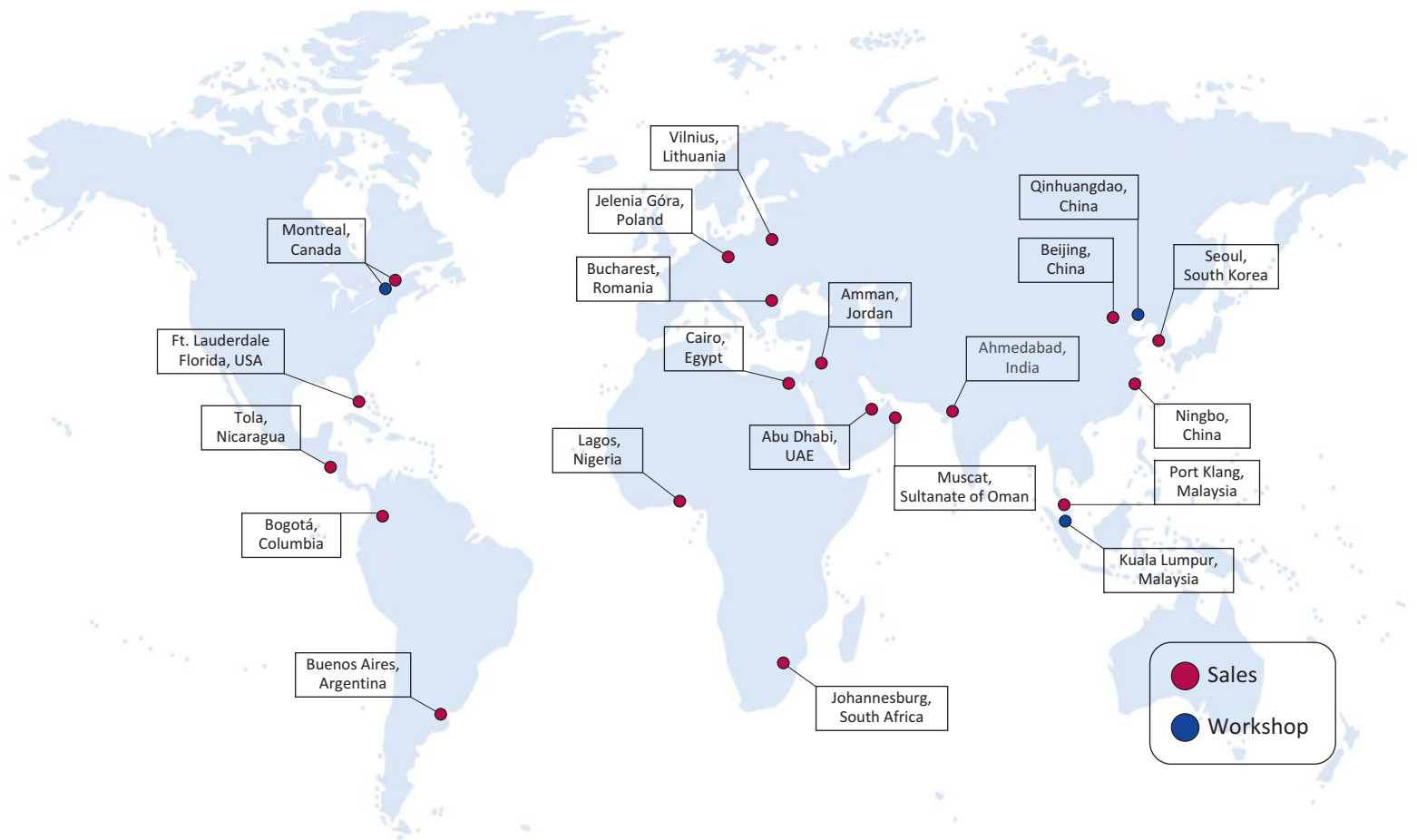

www.thorburnflex.com